



Ruijie RG-S2900G-E V3 Series Switches

Hardware Installation and Reference Guide V1.04

Copyright Statement

Ruijie Networks©2019

Ruijie Networks reserves all copyrights of this document. Any reproduction, excerption, backup, modification, transmission, translation or commercial use of this document or any portion of this document, in any form or by any means, without the prior written consent of Ruijie Networks is prohibited.

Exemption Statement

This document is provided "as is". The contents of this document are subject to change without any notice. Please obtain the latest information through the Ruijie Networks website. Ruijie Networks endeavors to ensure content accuracy and will not shoulder any responsibility for losses and damages caused due to content omissions, inaccuracies or errors.

Preface

Thank you for using our products. This manual will guide you through the installation of the device.

This manual describes the functional and physical features and provides the device installation steps, hardware troubleshooting, module technical specifications, and specifications and usage guidelines for cables and connectors.

Audience

It is intended for the users who have some experience in installing and maintaining network hardware. At the same time, it is assumed that the users are already familiar with the related terms and concepts.

Obtaining Technical Assistance

- Ruijie Networks Website: <https://www.ruijienetworks.com/>
- Technical Support Website: <https://ruijienetworks.com/support>
- Case Portal: <https://caseportal.ruijienetworks.com>
- Community: <https://community.ruijienetworks.com>
- Technical Support Email: service_rj@ruijienetworks.com
- Skype: [service_rj@ruijienetworks.com](https://www.skype.com/people/service_rj@ruijienetworks.com)

Related Documents

Documents	Description
Configuration Guide	Describes network protocols and related mechanisms that supported by the product, with configuration examples.
Command Reference	Describes the related configuration commands, including command modes, parameter descriptions, usage guides, and related examples.

Symbol Conventions



Means reader take note. Notes contain helpful suggestions or references.



Means reader be careful. In this situation, you might do something that could result in equipment damage or loss of data.

1 Product Overview

RG-S2900G-E V3 Series switch is a next-generation security and intelligent switch that features high performance, high security, multiple services and ease of use to meet the needs of the current networks. The RG-S2900G-E V3 switch can provide the complete end-to-end Quality of Service (QoS), flexible and abundant security policies and policy-based network management for various networks. They are the desired access devices for such applications as campus network, enterprise network, government network, service network, residential broadband access and business building network, providing high-speed, high-efficiency, secure and intelligent access solutions.

● Table 1-1 RG-S2900G-E V3 Series

Model	10/100/1000 BASE-T adaptive Ethernet Port	1000BASE-X SFP Port	Console Port	USB Port	Extension Module Slot	Pluggable Power Supply Module Slot
RG-S2928G-E V3	24	4	1	N/A	N/A	N/A
RG-S2952G-E V3	48	4	1	N/A	N/A	N/A

 SFP ports support 1000BASE-X.

 1000BASE-T is compatible with 100BASE-TX and 10BASE-T in the downlink direction.

1.1 RG-S2928G-E V3

Technical Specifications

Model	RG-S2928G-E V3
CPU	Built-in CPU, single-core processor with the clock speed of 1.0GHz
BOOTROM	N/A
Flash Memory	256MB
SDRAM	DDRIII 512MB
SFP Type	Support SFP optical modules. Refer to Appendix B for more information. The supported module type may change at any time. Consult us for the detailed change information.
SFP Port	Support 1000BASE-X Support stack module: GE-SFP-STACK1.6M
Power Supply	AC input: Rated voltage range: 100V to 240V Maximum voltage range: 90V to 264V Frequency: 50Hz/60Hz Rated current: 0.6A HVDC input:

	Rated voltage range: 192V to 290V Rated current range: 0.1A to 0.5A
Earth Leakage Current	≤3.5mA
EEE	Supported
PoE	Not supported
Power Consumption	≤ 24W
Working Temperature	0°C to 50°C (32°F to 122°F)
Storage Temperature	-40°C to 70°C (-40°F to 158°F)
Working Humidity	10% to 90% RH
Storage Humidity	5% to 95% RH
Fan	N/A
Temperature Warning	Supported
EMC Standards	GB9254-2008
Safety Standards	GB4943-2011
Dimensions (W x D x H)	443mm x 268mm x 44.5mm
Weight	≤ 3.5kg



RG-S2928G-E V3 switch is a class A product. In a domestic environment, this product may cause radio interference in which case the user may be required to take adequate measures.

Product Appearance

The front panel of the RG-S2928G-E V3 full gigabit Ethernet switch provides one RJ45 Console port, 24 RJ45 10/100/1000BASE-T Ethernet adaptive ports and four SFP ports. Figure 1-1 shows the appearance of the RG-S2928G-E V3.

Figure 1-1 Appearance of the RG-S2928G-E V3

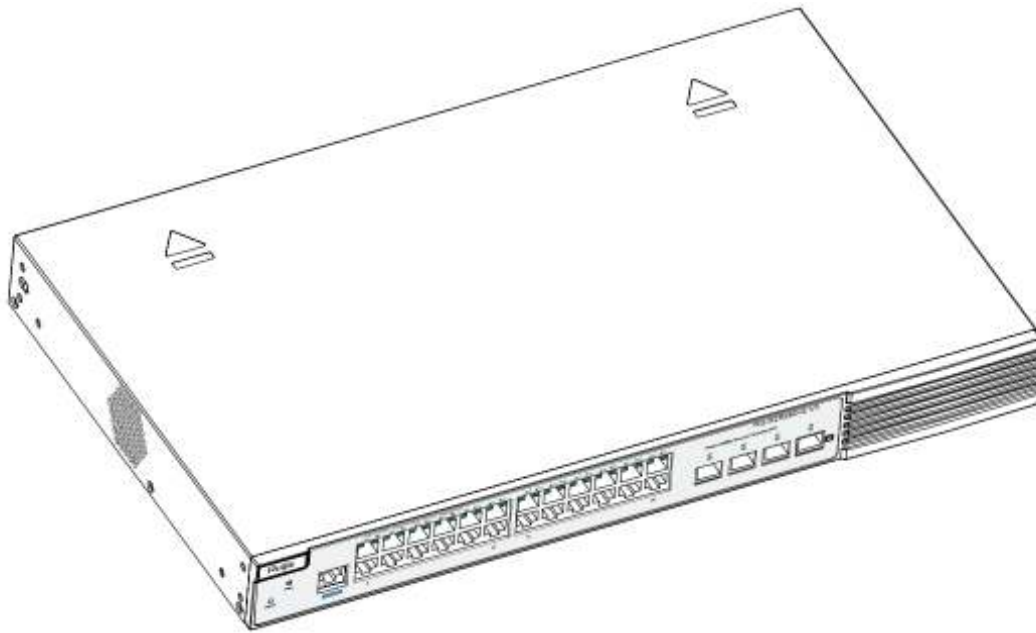

Front Panel

Figure 1-2 Front Panel of the RG-S2928G-E V3

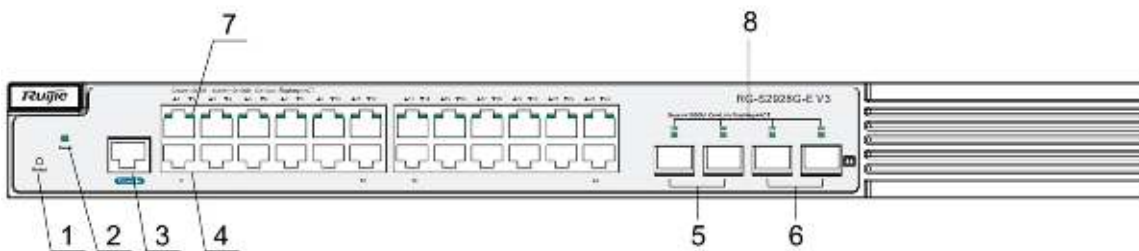

- Note:
- | | |
|--|--|
| 1. Reset button | 5. SFP ports |
| 2. System status indicator | 6. SFP ports |
| 3. Console port | 7. 10/100/1000BASE-T adaptive Ethernet port indicators |
| 4. 10/100/1000BASE-T adaptive Ethernet ports | 8. SFP port indicators |

Back Panel

Figure 1-3 Back Panel of the RG-S2928G-E V3

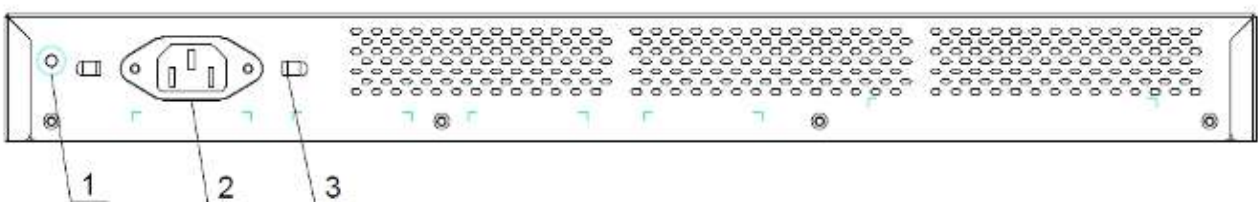

Note: 1. Grounding pole
2. Three-hole AC power receptacle
3. Power cord retention clips

Power Supply

The RG-S2928G-E V3 switch can be powered either with AC power or HVDC power.

- AC input:

Rated voltage range: 100V to 240V, 50Hz/60Hz

Maximum voltage range: 90V to 264V, 47Hz to 63Hz

Frequency: 50Hz/60Hz

Rated current: 0.6A

Power cord: 10A power cord

- HVDC input:

Rated voltage range: 192V to 290V

Rated current range: 0.1A to 0.5A

Heat Dissipation

The RG-S2928G-E V3 full gigabit switch is designed with no fans. To ensure good dissipation, sufficient space (10 cm distance from both sides and the back panel of the chassis) should be reserved for ventilation. Dust the device every three months to avoid blocking the ventilation openings.

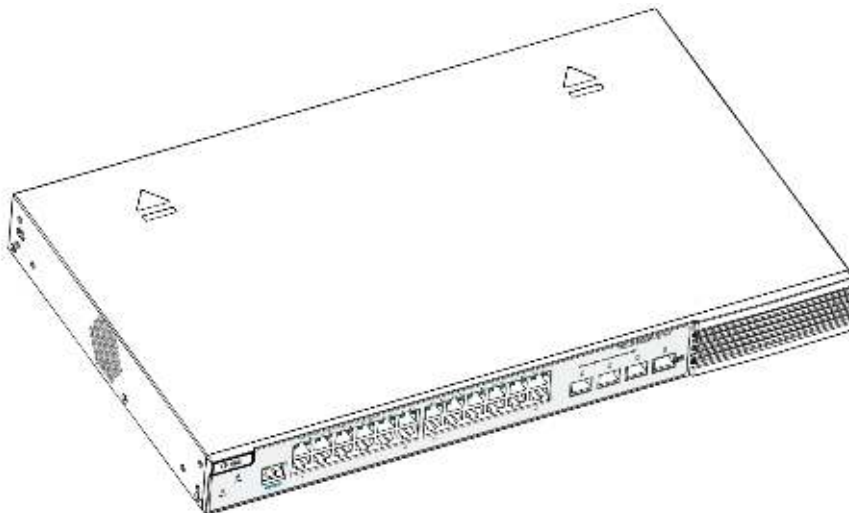

i When installing the device, sufficient ventilation space (1U (44.45mm) distance from the adjacent device) should be reserved for the purpose of heat dissipation.

LED Indicators

Indicator	Faceplate Marker	Status	Indication
Status indicator	Status	Blinking green	The system is being initialized.

Indicator	Faceplate Marker	Status	Indication
		Solid green	The system is in normal operation. .
		Solid red	1. Over-temperature alarm. Serious over-temperature causes system restart. 2. The system is faulty.
10/100/1000BASE-T adaptive Ethernet port indicators	1~24	Off	The port is NOT connected.
		Solid green	The port is connected at 1000Mbps.
		Solid yellow	The port is connected at 100/10Mbps.
		Blinking	The port is transmitting or receiving data.
SFP port indicators	25F~28F	Off	The port is NOT connected.
		Solid green	The port is connected.
		Blinking	The port is transmitting or receiving data.

1.2 RG-S2952G-E V3

Technical Specifications

Model	RG-S2952G-E V3
CPU	Built-in CPU, single-core processor with the clock speed of 1.0GHz
BOOTROM	N/A
Flash Memory	256MB
SDRAM	DDRIII 512MB
SFP Type	Support SFP optical modules. Refer to Appendix B for more information.  The supported module type may change at any time. Consult us for the detailed change information.
SFP Port	Support 1000BASE-X Support stack module: GE-SFP-STACK1.6M
Power Supply	<ul style="list-style-type: none"> AC input: Rated voltage range: 100V to 240V Maximum voltage range: 90V to 264V Frequency: 50 Hz/60 Hz Rated current: 1.5A HVDC input: Rated voltage range: 192V to 290V Rated current range: 0.5A to 0.78A
Earth Leakage Current	≤3.5mA
EEE	Supported
PoE	Not supported
Power	≤ 40W

Consumption	
Working Temperature	0°C to 50°C (32°F to 122°F)
Storage Temperature	-40°C to 70°C (-40°F to 158°F)
Working Humidity	10% to 90% RH
Storage Humidity	5% to 95% RH
Fan	Support adjustment of fan speed and warning of fan troubles
Temperature Warning	Supported
EMC Standards	GB9254-2008
Safety Standards	GB4943-2011
Dimensions (W x D x H)	443mm x 268mm x 44.5mm
Weight	≤ 4kg

⚠ RG-S2952G-E V3 switch is a class A product. In a domestic environment, this product may cause radio interference in which case the user may be required to take adequate measures.

Product Appearance

The front panel of the RG-S2952G-E V3 full gigabit Ethernet switch provides one RJ45 Console port, 48 RJ45 10/100/1000BASE-T adaptive Ethernet ports and four SFP ports. Figure 1-4 shows the appearance of the RG-S2952G-E V3.

Figure 1-4 Appearance of the RG-S2952G-E V3

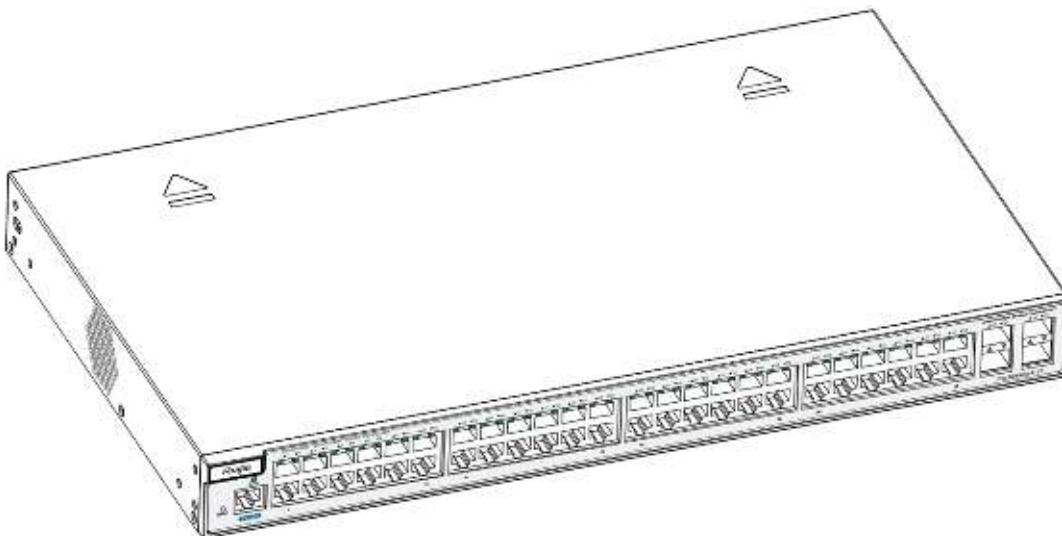

Front Panel

Figure 1-5 Front Panel of the RG-S2952G-E V3

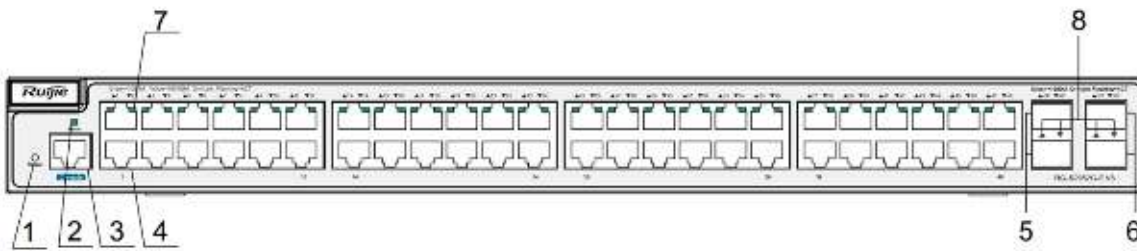

Note:	1. Reset button	5. SFP ports
	2. System status indicator	6. SFP ports
	3. Console port	7. 10/100/1000BASE-T adaptive Ethernet port indicators
	4. 10/100/1000 BASE-T adaptive Ethernet ports	8. SFP port indicators

Back Panel

Figure 1-6 Back Panel of the RG-S2952G-E V3



Note:	1. Grounding pole	3. Power cord retention clips
	2. Three-hole AC power receptacle	

Power Supply

The RG-S2952G-E V3 can be powered either with AC power or HVDC power.

- AC input:

Rated voltage range: 100V to 240V, 50Hz/60Hz

Maximum voltage range: 90V to 264V, 47Hz to 63Hz

Frequency: 50Hz/60Hz

Rated current: 1.5A

Power cord: 10A power cord

- HVDC input:

Rated voltage range: 192V to 290V

Rated current range: 0.5A to 0.78A

Heat Dissipation

The RG-S2952G-E V3 full gigabit switch adopts fans for heat dissipation, thereby ensuring the device to function normally in the specified environment. Sufficient space (10 cm distance from both sides and the back panel of the chassis) should be reserved for ventilation. Dust the device every three months to avoid blocking the ventilation openings.

Figure 1-7 Heat Dissipation of the RG-S2952G-E V3

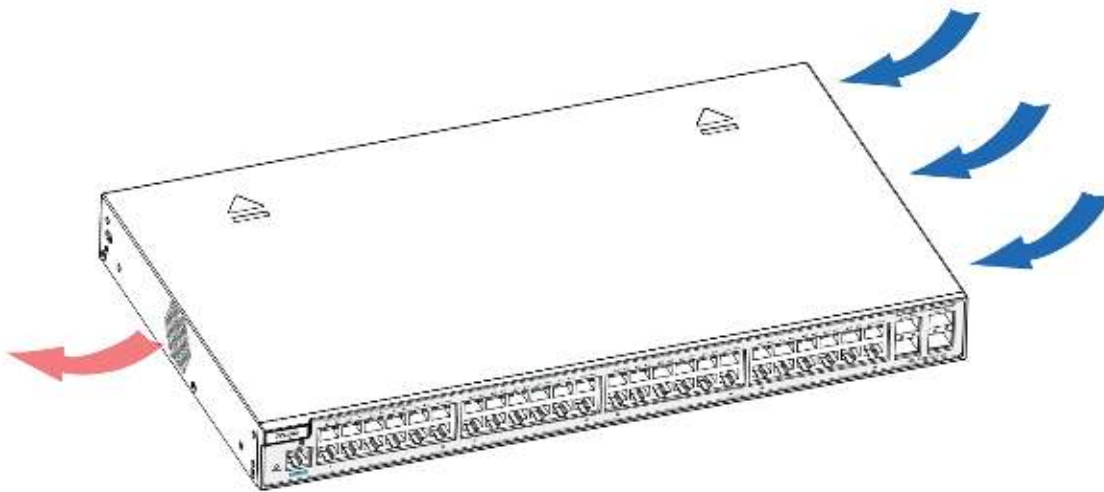



LED Indicators

Indicator	Faceplate Marker	Status	Indication
Status indicator	Status	Blinking green	The system is being initialized.
		Solid green	The system is in normal operation.
		Solid red	1. Over-temperature alarm. Serious over-temperature causes system restart. 2. The system is faulty.
10/100/1000Mbps RJ-45 port indicator	1~48	Off	The port is NOT connected.
		Solid green	The port is connected at 1000Mbps.
		Solid yellow	The port is connected at 100/10Mbps.
		Blinking	The port is transmitting or receiving data.
SFP port indicator	49F~52F	Off	The port is NOT connected.
		Solid green	The port is connected.
		Blinking	The port is transmitting or receiving data.

2 Preparation before Installation

2.1 Safety Suggestions

-
-  To avoid personal injury and equipment damage, please carefully read the safety suggestions before you install the RG-S2900G-E V3 series.
 -  The following safety suggestions do not cover all possible dangers.
-

2.1.1 Safety Precautions for Installing the System

- Keep the chassis clean and free from any dust.
- Do not place the equipment in a walking area.
- Do not wear loose clothes or accessories that may be hooked or caught by the device during installation and maintenance.
- Turn off all power supplies and remove the power sockets and cables before installing or uninstalling the device.

2.1.2 Movement Safety

- Do not frequently move the device.
- When moving the device, note the balance and avoid hurting legs and feet or straining the back.
- Before moving the device, turn off all power supplies and dismantle all power modules.

2.1.3 Electric Safety

- Observe local regulations and specifications when performing electric operations. Relevant operators must be qualified.
- Before installing the device, carefully check any potential danger in the surroundings, such as ungrounded power supply, and damp/wet ground or floor.
- Before installing the device, find out the location of the emergency power supply switch in the room. First cut off the power supply in the case of an accident.
- Try to avoid maintaining the switch that is powered-on alone.
- Be sure to make a careful check before you shut down the power supply.
- Do not place the equipment in a damp location. Do not let any liquid enter the chassis.

 Any nonstandard and inaccurate electric operation may cause an accident such as fire or electrical shock, thus causing severe even fatal damages to human bodies and equipment.

 Direct or indirect touch through a wet object on high-voltage and mains supply may bring a fatal danger.

 If a power supply system is equipped with a leakage protector (also referred to as "leakage current switch" or "leakage current breaker"), the rated leakage action current of each leakage protector is greater than twice of the

theoretical maximum leakage current of all the power supplies in the system. For example, if a system is equipped with eight identical power supplies, the leakage current of each power supply is equal to or less than 3 mA, and the leakage current of the system totals 24 mA. A leakage protector with 30 mA rated action current supports less than five power supplies (that is, Action current of the leakage protector/2/Maximum leakage current of each power supply = $30/2/3 = 5$). In other words, the leakage protector with 30 mA rated action current supports no more than four power supplies. In this case, the eight power supplies in the system require at least two leakage protectors with 30 mA rated action current and each leakage protector supports four power supplies. If power supplies in a system differ in models, the rated leakage action current of each leakage protector divided by two is greater than the sum of maximum leakage current of all the power supplies. The rated leakage non-action current of a leakage protector shall be 50% of the leakage action current. Take a leakage protector with 30 mA rated leakage action current as an example. The rated leakage non-action current shall be 15 mA. When the leakage current is below 15 mA, the protector shall not act. Otherwise, misoperation may easily occur due to high sensitivity and thus the leakage protector trips, devices are powered off, and services are interrupted.



To guarantee personal safety, the rated leakage action current of each leakage protector in the system must be equal to or less than 30 mA (human body safety current is 30 mA). When twice of the total leakage current of the system is greater than 30 mA, the system must be equipped with two or more leakage protectors.



For the leakage current value of each power supply model, see the power supply model parameter table in Chapter 1.

2.1.4 Static Discharge Damage Prevention

To prevent damage from static electricity, pay attention to the following:

- Proper grounding of grounding screws on the back panel of the device. Use of a three-wire single-phase socket with protective earth wire (PE) as the AC power socket.
- Indoor dust prevention.
- Proper humidity conditions.

2.1.5 Laser Safety

The RG-S2900G-E V3 series switch supports varying models of optical modules sold on the market which are Class I laser products. Improper use of optical modules may cause damage. Therefore, pay attention to the following when you use them:

- When a fiber transceiver works, ensure that the port has been connected with an optical fiber or is covered with a dust cap, to keep out dust and avoid burning your eyes.
- When the optical module is working, do not pull out the fiber cable and stare into the transceiver interface or you may hurt your eyes.



Do not stare into any optical port under any circumstances, as this may cause permanent damage to your eyes.

2.2 Installation Site Requirements

To ensure the normal working and a prolonged durable life of the equipment, the installation site must meet the following requirements.

2.2.1 Ventilation Requirements

For the RG-S2900G-E V3 series, you must ensure that sufficient space (10 cm distance from both sides and the back panel of the cabinet) is reserved at the ventilation openings to ensure the normal ventilation. During the jumper process of the device, prevent the cables from blocking the air intake. Dust the device every three months to avoid blocking the ventilation openings.

2.2.2 Temperature and Humidity Requirements

To ensure the normal operation and prolong the service life of RG-S2900G-E V3 series, you should keep proper temperature and humidity in the equipment room.

If the equipment room has temperature and humidity that do not meet the requirements for a long time, the equipment may be damaged.

- In an environment with high relative humidity, the insulating material may have bad insulation or even leak electricity. Sometimes the materials may suffer from mechanical performance change and metallic parts may get rusted.
- In an environment with low relative humidity, however, the insulating strip may dry and shrink. Static electricity may occur easily and endanger the circuit on the equipment.
- In an environment with high temperature, the equipment is subject to even greater harm, as its performance may degrade significantly and various hardware faults may occur. .

Therefore, the ambient temperature and humidity of the RG-S2900G-E V3 must meet the requirements listed in Table 2-1:

Table 2-1 Temperature and Humidity Requirements of the RG-S2900G-E V3 Series

Temperature	Relative Humidity
0°C to 50°C (32°F to 122°F)	10% to 90% RH

 The requirements for the sampling site of the temperature and humidity in the operating environment of the device are as follows:

There is no protective plate at the front or back of the equipment rack.

The vertical height is 1.5 m above the floor.

The distance from the front panel of the equipment is 0.4 m.

2.2.3 Cleanness Requirements

Dust poses a severe threat to the running of the equipment. The indoor dust falling on the equipment may be adhered by the static electricity, causing bad contact of the metallic joint. Such electrostatic adherence may occur more easily when the relative humidity is low, not only affecting the useful life of the equipment, but also causing communication faults.

Table 2-2 shows the requirements for the dust content and granularity in the equipment room.

Table 2-2 Requirements for the Dust Content and Granularity in the Equipment Room

Substance	Concentration Limit (particles/m3)
Dust particles (diameter $\geq 0.5\mu\text{m}$)	$\leq 3.5 \times 10^6$
Dust particles (diameter $\geq 5\mu\text{m}$)	$\leq 3 \times 10^4$

Apart from dust, the salt, acid and sulfide in the air in the equipment room must also meet strict requirements; as such poisonous substances may accelerate the corrosion of the metal and the aging of some parts. The equipment room should be protected from the intrusion of harmful gases (for example, SO_2 , H_2S , NO_2 and Cl_2), whose requirements are listed in the following table.

Table 2-3 Requirements for Harmful Gases in the Equipment Room

Gas	Average (mg/m3)	Maximum (mg/m3)
SO_2	0.3	1.0
H_2S	0.1	0.5
NO_2	0.5	1.0
Cl_2	0.1	0.3

 The **Average** refers to the average limit of harmful gas in one week. The **Maximum** value is the upper limit of the harmful gas measured in one week for up to 30 minutes every day.

2.2.4 EMI

During applications, the switch may be subject to external interferences that affect the device through conduction manners such as capacitance coupling, inductive coupling, electromagnetic wave emission, common impedance (including grounding systems), and wires (power cables, signal cables and outgoing transmission cables). For that purpose, note that:

- For the AC power supply system TN, single-phase three-core power socket with protective earthing conductors (PE) should be adopted to effectively filter out interference from the power grid through the filtering circuit.
- The switch should be located at places free from large power radio launch pad, radar launch pad, and high-frequency large-current devices.
- If necessary, electromagnetic shielding should be adopted. For example, use interface cables to shield cables.
- Interface cables should be laid inside the equipment room. Outdoor cabling is prohibited, avoiding damages to device signal interfaces caused by over-voltage or over-current of lightning.

2.2.5 System Grounding Requirements

A good grounding system is the basis for the stable and reliable operation of the RG-S2900G-E V3 series. It is the chief condition to prevent lightning stroke and resist interference. Please carefully check the grounding conditions on the installation site according to the grounding requirements, and perform grounding operations properly as required.

 Effective grounding of the switch is an important guarantee for lightning protection and interference resistance. Therefore, connect the grounding line of the switch properly.

Safety Grounding

The equipment using AC power supply must be grounded by using the yellow/green safety grounding cable. Otherwise, when the insulating resistance decreases the power supply and the enclosure in the equipment, electric shock may occur.

- ⚠ Ensure that a protective earth wire is provided in the building.
- ⚠ A service person should check whether or not the socket-outlet from which the device is to be powered provides a reliable connection to the building protective earth. If not, the service person should arrange for the installation of a protective earthing conductor from the separate protective earthing terminal to the protective earth wire in the building.
- ⚠ The socket-outlet should be installed at a location near the device easy for operation.
- ⚠ During the device installation, always make the ground connected first and disconnected last.
- ⚠ The cross-sectional area of protective earthing conductor should be at least 0.75mm^2 (18AWG).
- ⚠ Use three-pin power cord for installation. The cross-sectional area of each pin should be at least 0.75mm^2 (18AWG).

Lightning Grounding

The lightning protection system of a facility is an independent system that consists of the lightning rod, downlead conductor and the connector to the grounding system, which usually shares the power reference ground and yellow/green safety cable ground. The lightning discharge ground is for the facility only, irrelevant to the equipment.

EMC Grounding

The grounding required for EMC design includes shielding ground, filter ground, noise and interference suppression, and level reference. All the above constitute the comprehensive grounding requirements. The resistance of earth wires should be less than 1 ohm. The RG-S2900G-E V3 backplane is reserved with one grounding pole, as shown in Figure 2-1.

Figure 2-1 Schematic Diagram of the RG-S2900G-E V3 Grounding

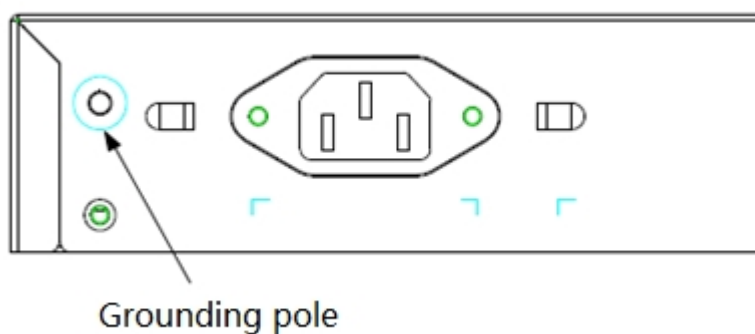

2.2.6 Lightning Resistance Considerations

When the AC power cable is imported outdoors and directly connected to the power port of the switch, lightning line bank should be adopted to prevent the switch from being hit by lightning shocks. Usage of the lightning line bank: Connect the mains supply AC cable to the lightning line bank. Then, connect the switch to the lightning line bank. This can help to

prevent the current of high-voltage lightning from passing the switch directly through the mains supply cable to a certain extent.

-
-  The lightning line banks are not provided and should be purchased by users as required.
For the usage of lightning line banks, refer to their related manuals.
-

2.2.7 EMI Consideration

Electro-Magnetic Interference (EMI), from either outside or inside the equipment or application system, affects the system in the conductive ways such as capacitive coupling, inductive coupling, and electromagnetic radiation.

There are two types of electromagnetic interferences: radiated interference and conducted interference, depending on the type of the transmission path.

When the energy, often RF energy, from a component arrives at a sensitive component via the space, the energy is known as radiated interference. The interference source can be either a part of the interfered system or a completely electrically isolated unit. Conducted interference results from the electromagnetic wire or signal cable connection between the source and the sensitive component, along which cable the interference conducts from one unit to another. Conducted interference often affects the power supply of the equipment, but can be controlled by a filter. Radiated interference may affect any signal path in the equipment and is difficult to shield.

- Effective measures should be taken for the power system to prevent the interference from the electric grid.
- The grounding device of the switch must not be used as the grounding device of the electrical equipment or anti-lightning grounding device. In addition, the grounding device of the switch must be deployed far away from the grounding device of the electrical equipment and anti-lightning grounding device.
- Keep the equipment away from high-power radio transmitter, radar transmitting station, and high-frequency large-current device.
- Measures must be taken to shield static electricity.

2.3 Requirements of Installation Tools

Table 2-4 List of Installation Tools

Common tools	Philips screwdriver, flathead screwdriver, related electric cables and optical cables, bolts, diagonal pliers, straps
Special tools	Anti-static tools
Meters	Multimeter

-
-  The tool kit is customer supplied.
-

3 Product Installation

- i** Please ensure that you have carefully read the section of “Preparation before Installation”.
Make sure that the requirements set forth in section of “Preparation before Installation” have been met.

3.1 Installation Procedure

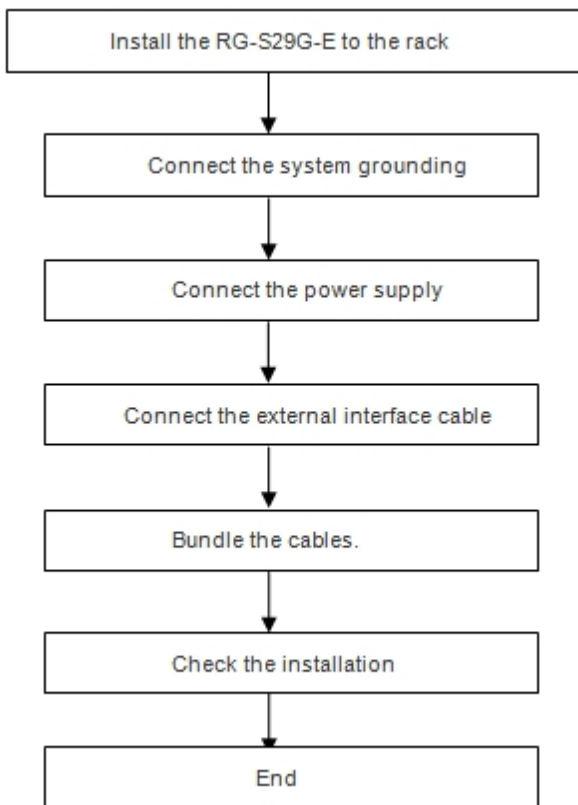

3.2 Confirmations before Installation

Before installation, please confirm the following points:

- Whether ventilation requirements are met for the switch
- Whether the requirements of temperature and humidity are met for the switch
- Whether power cables are already laid out and whether the requirements of electrical current are met
- Whether related network adaption lines are already laid out

3.3 Installing the RG-S2900G-E V3 Series

Precautions

During installation, note the following points:

- Connect the power cables of different colors to the corresponding grounding posts.
- Ensure that the interface of the power supply cable is well connected to the power interface of the device. The power cables must be protected using power cable retention clips after they are connected to the device.
- Do not place any articles on the RG-S2900G-E V3 series switch.
- Reserve a spacing of at least 10 cm around the chassis for good ventilation. Do not stack the devices.
- The switch should be located at places free from the large power radio launch pad, radar launch pad, and high-frequency large-current devices. If necessary, electromagnetic shielding should be adopted. For example, use interface cables to shield cables.
- 100-meter network cables should be laid inside the equipment room and outdoor cabling of such cables is prohibited. If outdoor cabling is necessary, take relevant measures for lightning protection.

3.3.1 Mounting the Switch in the Rack

The RG-S2900G-E V3 series switches are designed with the EIA standard dimensions and can be installed in 19-inch rack.

Step 1: Take out supplied screws and brackets, and then mount the brackets onto left and right sides of the switch.

Figure 3-2 Attaching the Mounting Brackets to the Switch

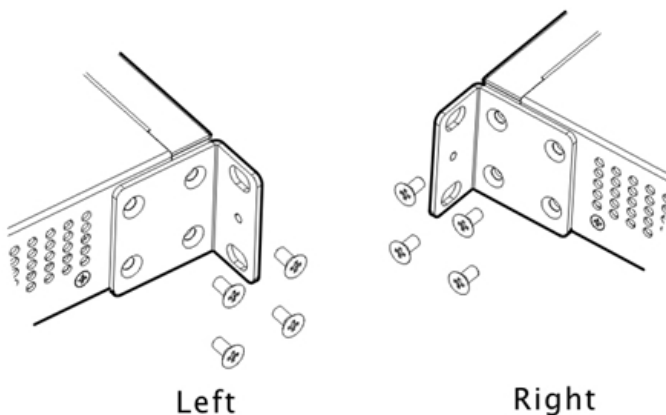

Step 2: Place the switch into the rack. Fix the other ends of both brackets onto the square hole strips of the rack by using M6 screws and cage nuts, as shown in Figure 3-3 and Figure 3-4.

Figure 3-3 Fixing the Brackets to the Rack

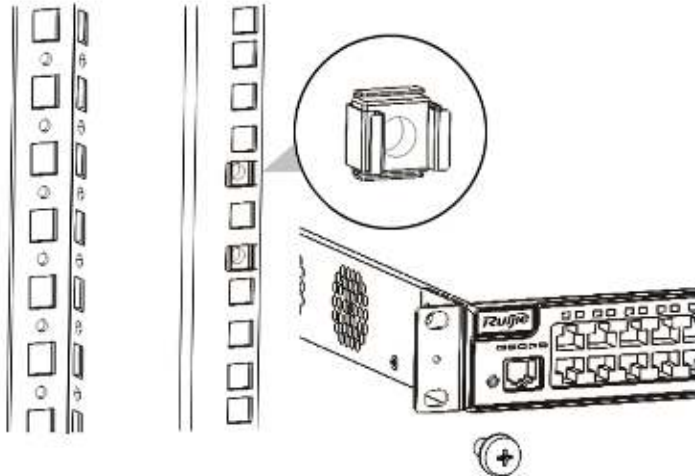
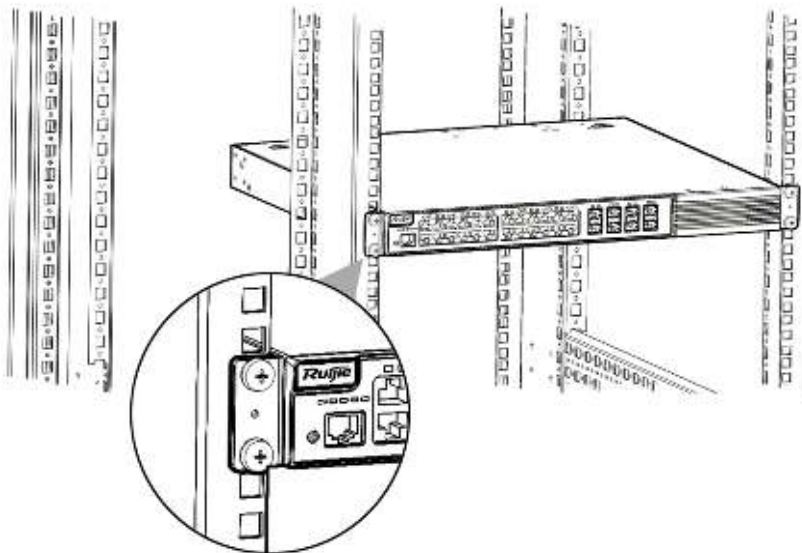

Figure 3-4 Fixing the Brackets to the Rack



3.3.2 Mounting the Switch on the Wall

The RG-S2900G-E V3 series switches can be mounted on a wall.

Step 1: Take out supplied screws and brackets. And then rotate the brackets by 90° when it is mounted on the wall.

Figure 3-5 Attaching the Mounting Brackets to the Switch for Wall-Mounting

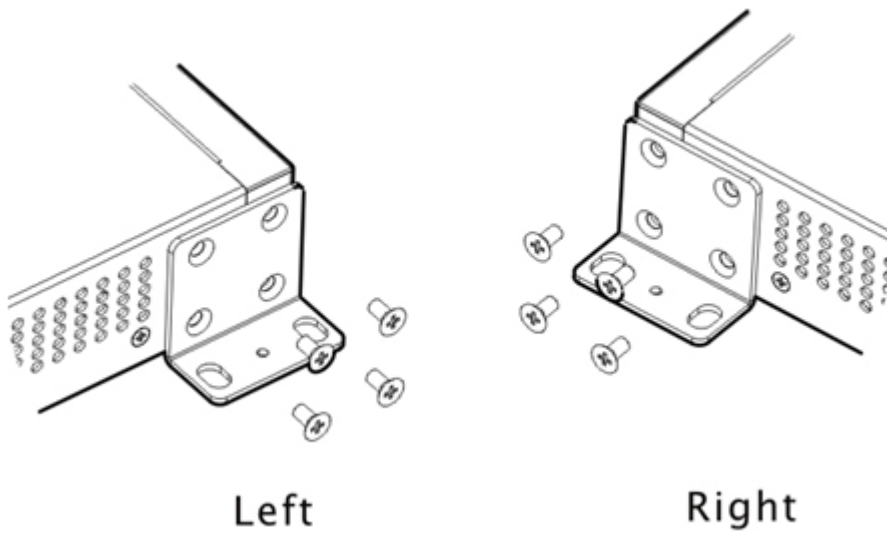

Step 2: Fix the switch onto the wall by using expansion screws.

Figure 3-6 Fixing the Switch to the Wall

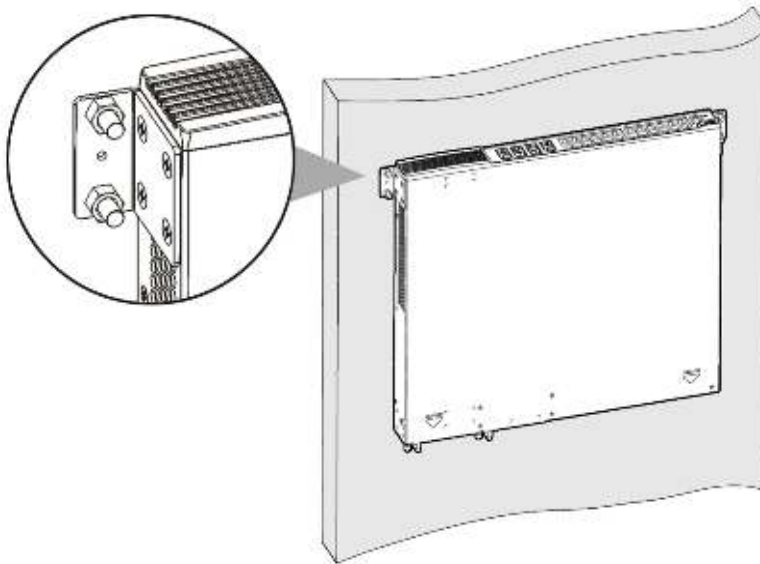

i The RG-S2900G-E V3 series switch is suitable for mounting on concrete or other non-combustible surface only.

3.3.3 Mounting the Switch to a Workbench

In some cases, users do not have the 19-inch standard cabinet. The common solution is to place the switch on a clean workbench. The operation is simple as follows:

Step 1: Attach the four rubber pads to the four corners on the switch bottom.

Figure 3-7 Attaching the Pads to the Switch

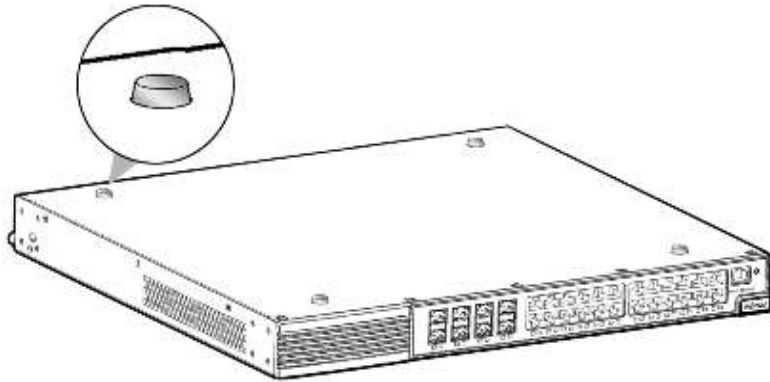

2) Step 2: Place the switch on the workbench and ensure good ventilation condition around the switch.

Figure 3-8 Placing the Switch on the Workbench

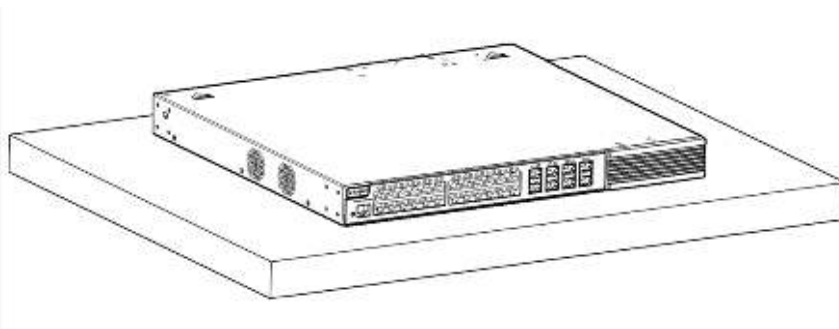

3.4 Checking after Installation



Before checking the installation, switch off the power supply so as to avoid any personal injury or damage to the component due to connection errors.

- Check that the ground line is connected.
- Check that the cables and power input cables are correctly connected.
- Check that the 100 meter cables are laid out inside the equipment room. In the case of external cabling, check that the lightning resistance socket or network interface lightning protector is connected.
- Check that sufficient ventilation space is available around the device (over 10 cm).

4 System Debugging

4.1 Establishing the Debugging Environment

Establishing the Debugging Environment

Connect the PC to the console port of the switch through the console cable, as shown in Figure 4-1.

Figure 4-1 Schematic Diagram of the Configuration Environment

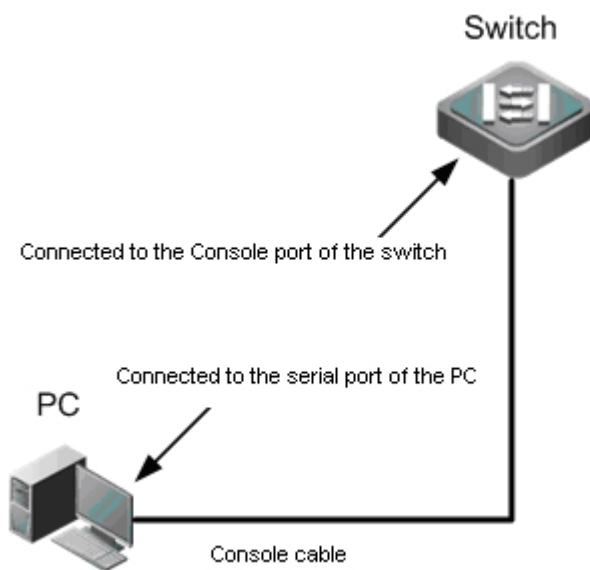

Connecting the Console Cable

- Step 1: Connect the end of the console cable with DB-9 jack to the serial port of the PC.
- Step 2: Connect the end of the console cable with RJ45 to the console port of the switch.

Setting HyperTerminal Parameters

- Step 1: Start the PC and run the terminal simulation program on the PC, such as Terminal on Windows 3.1 or HyperTerminal on Windows 95/98/NT/2000/XP.
- Step 2: Set terminal parameters. The parameters are as follows: baud rate 9600, data bit 8, parity check none, stop bit 1, and flow control as none.

Choose Setup > Program > Attachment > Communication > Hyper Terminal.

Choose **Cancel**, the interface as shown in Figure 4-2 is displayed.

Figure 4-2

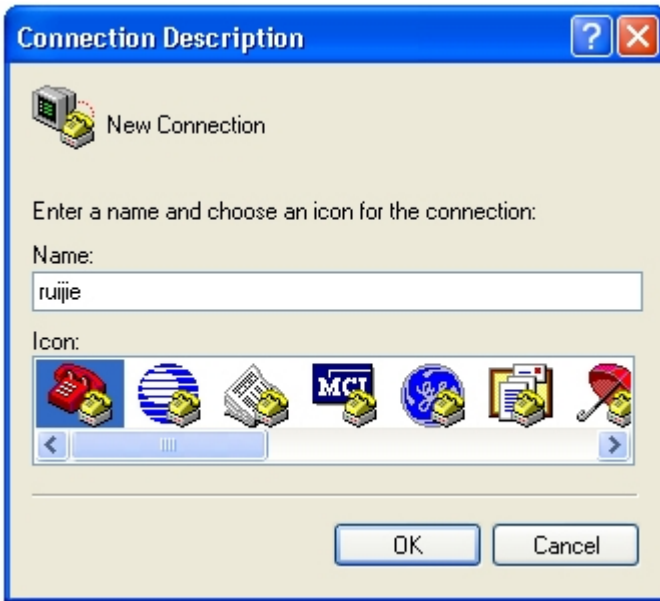

Enter the name of the new connection and click **OK**, the interface as shown in Figure 4-3 is displayed. Choose the serial port used currently in the column [use when connecting].

Figure 4-3



After choosing the serial port, click **OK** to display the serial port parameter setting interface, set the baud rate to 9600, data bit to 8, parity check to none, stop bit to 1 and flow control to none.

Figure 4-4

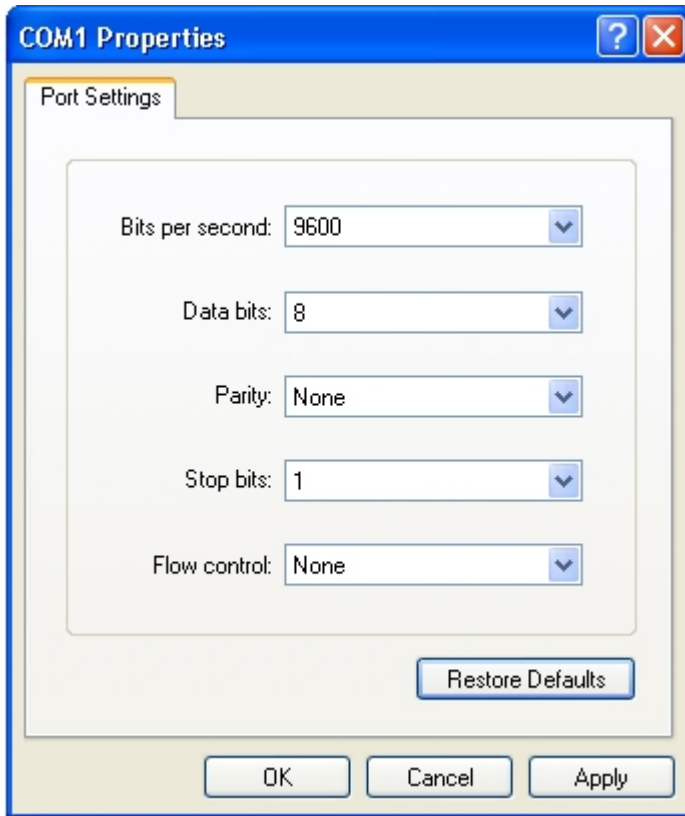

After setting the parameters, click **OK** to enter the hyper terminal interface.

4.2 Startup Check

4.2.1 Checking before the Device is Powered on

- The switch is fully grounded.
- The power cable is correctly connected.
- The power supply voltage complies with the requirement of the switch.
- The control cable of the PC is properly connected to the console port of the switch. The hyper terminal is started and the parameter settings are correct.

4.2.2 Checking after Program Startup (Recommended)

After power-on, you are recommended to perform the following checks to ensure the normal operation of follow-up configurations.

- Check whether information is displayed on the terminal interface.
- Check whether the status of the switch indicator is normal.
- Check whether the main program of the device is normally loaded.
- Check whether the time on the device is consistent with the current Beijing time.
- Check whether the service interfaces forwards data normally.

5 Maintenance and Troubleshooting

5.1 General Troubleshooting Procedure

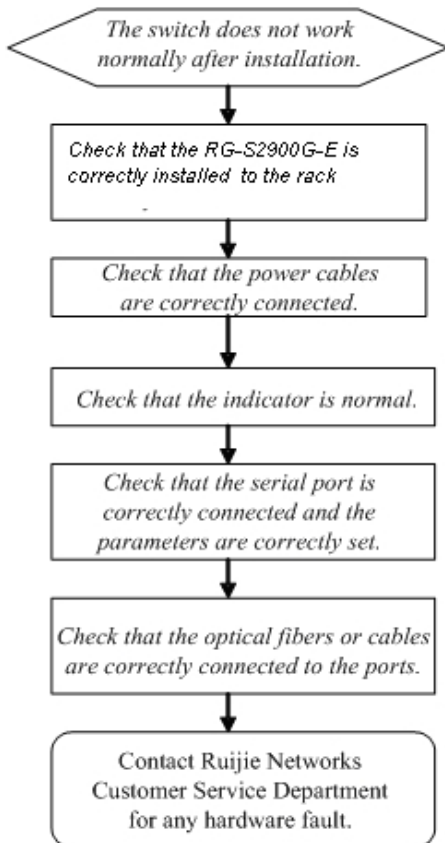

5.2 Troubleshooting Common Faults

Symptom	Possible Causes	Solution
Forgetting the management interface login password	A password is manually configured but it is forgotten.	Please contact Ruijie Networks Customer Service Department for technical support.
The status indicator is not on after the switch is started.	The power supply module does not supply power. The power cable is in loose contact.	Check whether the power socket at the equipment room is normal and whether the power cable of the switch is in good contact.
The status indicator is red.	Fan alarm Temperature alarm Power supply alarm	Check whether the fan is blocked or damaged. At this time, the switch already stops the normal service exchanges. Check in time the working environment of the switch, clean the dust on the cabinet and reinforce the refrigeration effect. Check whether the power cord is connected.

Symptom	Possible Causes	Solution
		Remove the non-working or faulty power supply.
The serial port console has no output or outputs illegible characters.	The serial port connected to the switch does not match that opened by the configuration software. The serial port is not configured correctly.	Change the serial port opened by the configuration software to be the one connected to the switch. Check that the parameter configuration of the serial port matches that specified in the instructions.
The RJ45 port is not in connectivity or it is erroneous in receiving/transmitting frames.	The connected twisted pair cable is faulty. The length of the cable exceeds 100 m. The port has special configuration that has no common working mode with the connected switch.	Replace the twisted pair cable. Check that the port configuration has the common working mode with the connected switch.
The fiber port cannot be connected.	The Rx and Tx ends are connected reversely. The interconnected optical module type does not match. The fiber type is not correct. The length of the optical fiber exceeds that rated of the optical module.	Switch the Rx and Tx ends of the optical fiber. Replace the optical module with one of the matched type. Replace the optical fiber with one of the appropriate type. Replace the optical fiber with one of the appropriate length.
The expansion module cannot be identified by the host.	The module is not properly inserted. The module is inserted while the host is receiving power.	Turn off the host. Reinsert the module before turning on the host again. Turn off the host. Remove and then insert the module.

Appendix A: Connectors and Connection Media

1000BASE-T/100BASE-TX/10BASE-T Ports

The 1000BASE-T/100BASE-TX/10BASE-T is a port that supports adaptation of three rates, and automatic MDI/MDIX Crossover at these three rates.

The 1000BASE-T complies with IEEE 802.3ab, and uses the cable of 100-ohm Category-5 or Supper Category-5 UTP or STP, which can be up to 100 m.

The 1000BASE-T port uses four pairs of wires for transmission, all of which must be connected. Figure A-1 shows the connections of the twisted pairs used by the 1000BASE-T port.

Figure A-1 Four Twisted Pairs of the 1000BASE-T

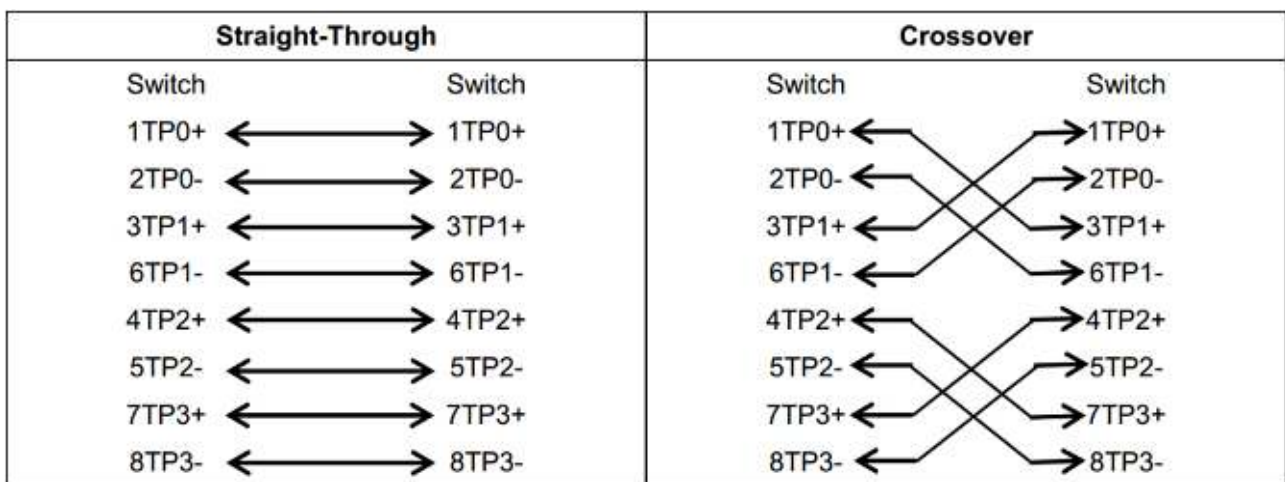

In addition to the above cables, the 100BASE-TX/10BASE-T can also use 100-ohm Category-3, 4, 5 cables for 10 Mbps, and 100-ohm Category-5 cables for 100 Mbps, both of which can be up to 100 m. Figure A-2 shows the pinouts of the 100BASE-TX/10BASE-T.

Figure A-2 Pinouts of the 100BASE-TX/10BASE-T

Pin	Socket	Plug
1	Input Receive Data+	Output Transmit Data+
2	Input Receive Data-	Output Transmit Data-
3	Output Transmit Data+	Input Receive Data+
6	Output Transmit Data-	Input Receive Data-
4,5,7,8	Not used	Not used

Figure A-3 shows the straight-through and crossover cable connections for the 100BASE-TX/10BASE-T.

Figure A-3 Connections of the Twisted Pairs of the 100BASE-TX/10BASE-T

Straight-Through		Crossover	
Switch	Switch	Switch	Switch
1 IRD +	1 OTD +	1 IRD +	1 OTD +
2 IRD -	2 OTD -	2 IRD -	2 OTD -
3 OTD +	3 IRD +	3 OTD +	3 IRD +
6 OTD -	6 IRD -	6 OTD -	6 IRD +

Optical Fiber Connection

For the optical fiber ports, select single-mode or multiple-mode optical fibers for connection according to the fiber module connected. The connection schematic diagram is shown in Figure A-4:

Figure A-4 Optical Fiber Connections



Appendix B: Mini-GBIC Modules

We provide appropriate SFP modules (Mini-GBIC) modules according to the types of interfaces of the switch modules. You can select the module to suit your specific needs. The 100M/1000M SFP module supports the following modules as well as the 100M/1000M fiber/copper conversion SFP module (Mini-GBIC-GT). The following models and technical specifications of some 100M/1000M SFP modules are listed for your reference.

Models and Technical Specifications of the Mini-GBIC (SFP) Module

Table B-1 Models and Technical Specifications of the 100M SFP Modules

100M Mini-GBIC (SFP)	Wavelength (nm)	Media Type	Core Size (μm)	Cabling Distance	Intensity of Transmitted Light (dBm)		Intensity of Received Light (dBm)		Support DDM (Yes/No)
					min	max	min	max	
FE-SFP-LX-MM1310	1,310	Multi-mode fiber	62.5/125	2km	-22	-14	-30	-14	Yes
FE-SFP-LH15-SM1310	1,310	Single-mode fiber	9/125	15km	-15	-8	-28	-8	Yes

Table B-2 Models and Technical Specifications of the 1000M SFP Modules

1000M Mini-GBIC (SFP)	Wavelength (nm)	Media Type	Core Size (μm)	Cabling Distance	Intensity of Transmitted Light (dBm)		Intensity of Received Light (dBm)		Support DDM (Yes/No)
					min	max	min	max	
MINI-GBIC-SX-MM850	850	Multi-mode fiber	62.5/125	275m	-9.5	-3	-17	0	No
			50/125	550m					
MINI-GBIC-LX-SM1310	1,310	Single-mode fiber	9/125	10km	-9.5	-3	-20	-3	No
GE-eSFP-SX-MM850	850	Multi-mode fiber	62.5/125	275m	-9.5	-3	-17	0	Yes
			50/125	550m					
GE-eSFP-LX-SM1310	1,310	Single-mode fiber	9/125	10km	-9.5	-3	-20	-3	Yes
MINI-GBIC-LH40-SM1310	1,310	Single-mode fiber	9/125	40km	-2	3	-22	-3	Yes
MINI-GBIC-ZX50-SM1550	1,550	Single-mode fiber	9/125	50km	-5	0	-22	-3	Yes
MINI-GBIC-ZX80-SM1550	1,550	Single-mode fiber	9/125	80km	0	4.7	-22	-3	Yes

MINI-GBIC-ZX100-SM1 550	1,550	Single-mode fiber	9/125	100km	0	5	-30	-9	Yes
----------------------------	-------	----------------------	-------	-------	---	---	-----	----	-----



 For the optical module with transmission distance exceeding 40 km and more, one on-line optical attenuator should be added on the link to avoid the overload of the optical receiver when short single-mode optical fibers are used.

Table B-3 Pairing of BIDI SFP Modules

Rate/Distance	Pairing Modules
1000M/20km	GE-SFP-LX20-SM1310-BIDI GE-SFP-LX20-SM1550-BIDI
1000M/40km	GE-SFP-LH40-SM1310-BIDI GE-SFP-LH40-SM1550-BIDI
100M/20km	FE-SFP-LX20-SM1310-BIDI FE-SFP-LX20-SM1550-BIDI
100M/40km	FE-SFP-LH40-SM1310-BIDI FE-SFP-LH40-SM1550-BIDI

 BIDI SFP modules have to be used in pairs. For instance, if GE-SFP-LX20-SM1310-BIDI is applied at one end, then GE-SFP-LX20-SM1550-BIDI has to be used at the other end.

Models and Technical Specifications of the Mini-GBIC-GT Module

Table B-4 The existing SFP copper modules:

Standard	1000BASE-T SFP Model
1000BASE-T	Mini-GBIC-GT

Table B-5 The cabling specifications of 1000BASE-T Ports

1000BASE-T	Copper Cable Type	Cabling Distance	Support DDM (Yes/No)
Mini-GBIC-GT	Cat 5 or above STP or UTP	100m	No

 For the optical module with transmission distance exceeding 40 km and more, one on-line optical attenuator should be added on the link to avoid the overload of the optical receiver when short single-mode optical fibers are used.

Appendix C: Lightning Protection

Installing AC Power Arrester (lightning protection cable row)

The external lightning protection cable row should be used on the AC power port to prevent the switch from being struck by lightning when the AC power cable is introduced from the outdoor and directly connected to the power port of the switch. The lightning protection cable row is fixed on the cabinet, operating table or the wall in the machine room using the line buttons and screws. AC enters the lightning protection cable row and then gets to the switch.

Figure C-1 Schematic Diagram for the Power Arrester

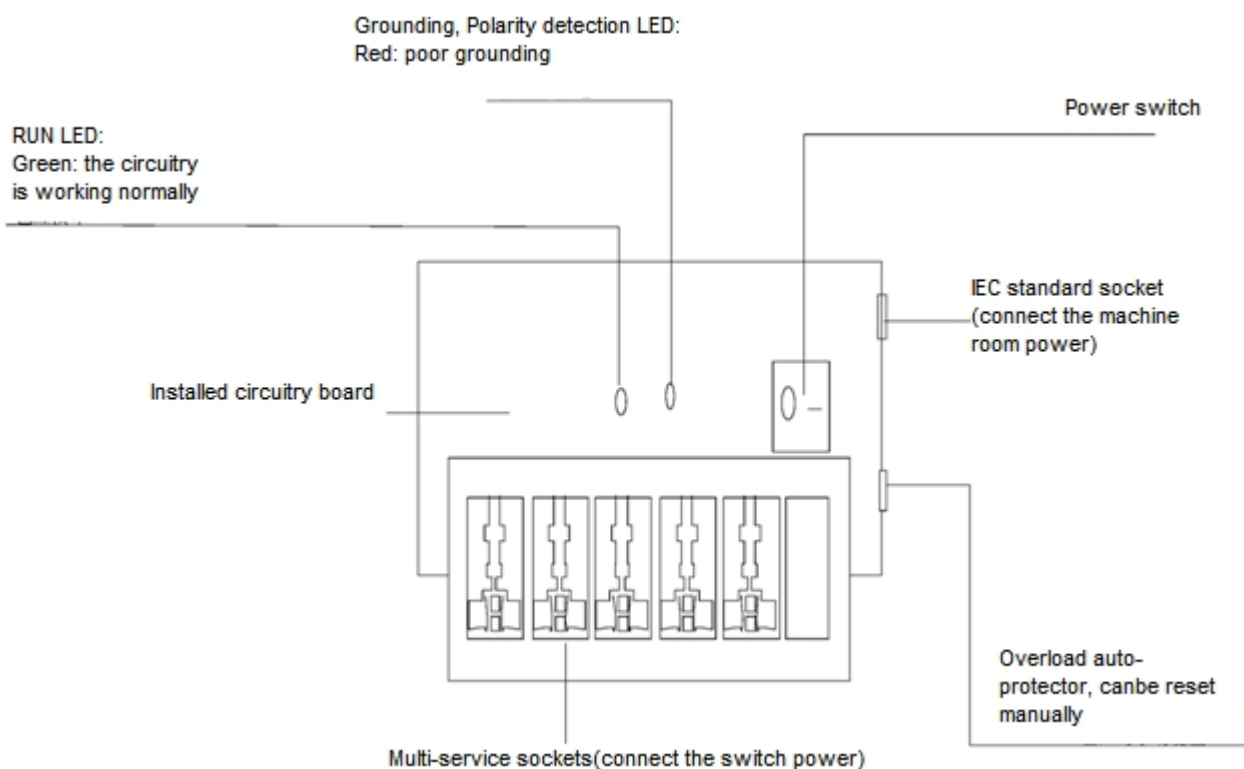

i The power arrester is not provided and the user should purchase it to address the practical requirement.

Precautions for installation:

- Make sure that the PE terminal of the power arrester has been well-grounded;
- After the switch AC power plug is connected to the socket of the power arrester (lightning protection cable row), lightning protection function implements if the RUN LED is Green and the ALARM LED is OFF.
- If the ALARM LED on the power arrester is Red, you should check whether it is caused by poor grounding connection or by the reversed connection of the Null and Live lines: Use the multimeter to check the polarity of the power socket for the arrester when the LED is Red, if the N line is on the left and the L line is on the right (facing the socket), the arrester PE terminal is not grounded; if the L line is on the left and the N line is on the right, the polarity of

the arrester power cable shall be reversed by the power arrester; if the LED is still Red, it is confirmed that the arrester PE terminal has not been grounded.

Installing the Ethernet Port Arrester

During the switch usage, the Ethernet port arrester should be connected to the switch to prevent the switch damage by lightning before the outdoor network cable connects to the switch .

Tools: Cross or straight screwdriver, Multimeter, Diagonal pliers

Installation Steps:

- 1) Tear one side of the protection paper for the double-sided adhesive tape and paste the tape to the framework of the Ethernet port arrester. Tear the other side of the protection paper for the double-sided adhesive tape and paste the Ethernet port arrester to the switch framework. The paste location for the Ethernet port arrester should be as close to the grounding terminal of the switch as possible.
- 2) Based on the distance of the switch grounding terminal, cut the grounding line for the Ethernet port arrester and firmly tighten the grounding line to the grounding terminal of the switch.
- 3) Use the multimeter to check whether the grounding line for the arrester is in good contact with the switch grounding terminal and the framework.
- 4) According to the description on the Ethernet Port Arrester Hardware Installation Guide, connect the arrester using the adapter cable(note that the external network cable is connected to the end of IN, while the adapter cable connected to the switch is connected to the end of OUT) and observe whether the LED on the board is normal or not.
- 5) Use the nylon button to bundle the power cables.

Figure C-2 Schematic Diagram for the Ethernet port Arrester Installation

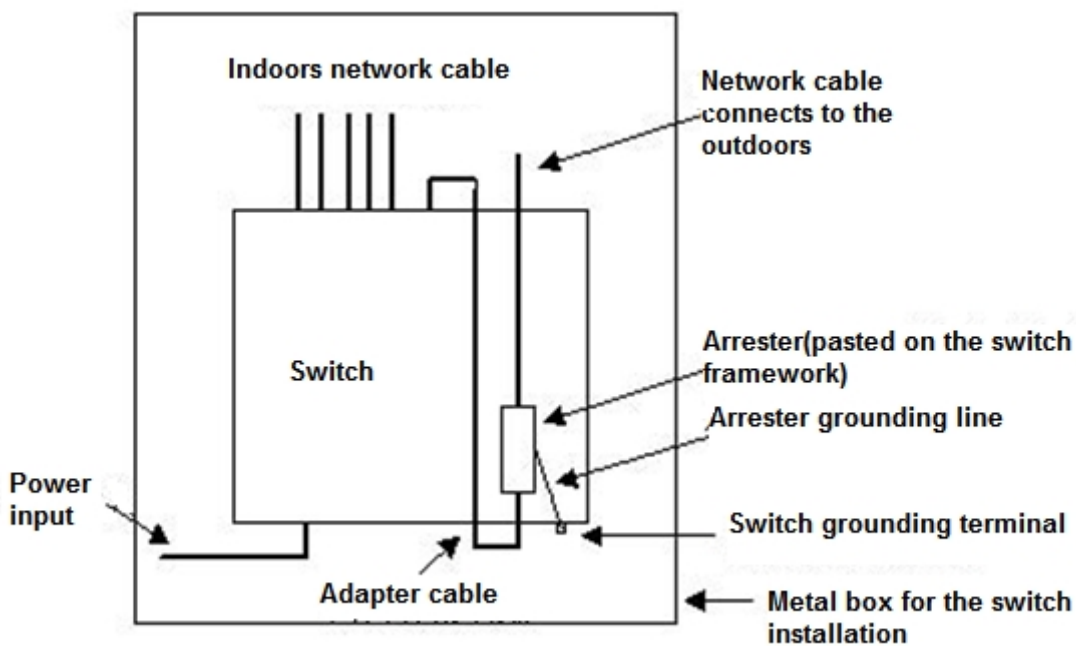

-
-  The Ethernet port arrester is not provided, the user can purchase them to address their own practical requirements. For the detailed information for the arrester installation, please refer to Ethernet Port Arrester Hardware Installation Guide, which contains the technical specification and the maintenance and installation of the arrester.
-

You should pay attention to the following conditions during the actual installation to avoid influencing the performance of the Ethernet port arrester:

- Reversed direction of the arrester installation. You shall connect the external network cable to the “IN” end and connect the switch Ethernet port to the “OUT” end.
- Poor arrester grounding. The length of the grounding line should be as short as possible to ensure that it is in good contact with the switch grounding terminal. Use the multimeter to confirm the contact condition after the grounding.
- Incomplete arrester installation. If there is more than one port connected to the peer device on the switch, it entails installation of arresters on all connection ports for the purpose of lightning protection.

Appendix D: Cabling Recommendations in Installation

When the switches are installed in standard 19-inch cabinets, the cables are tied in the binding rack on the cabinet by the cable management bracket, and top cabling or bottom cabling is adopted according to the actual situation in the equipment room. All cable connectors should be placed at the bottom of the cabinet in an orderly manner instead of outside the cabinet easy to touch. Power cables are routed beside the cabinet, and top cabling or bottom cabling is adopted according to the actual situation in the equipment room, such as the position of the DC power distribution box, AC socket, or lightning protection box.

Requirement for the Minimum Cable Bend Radius

- The bend radius of a power cord, communication cable, and flat cable should be over five times greater than their respective diameters. The bend radius of these cables that often bend or suffer removal/insertion should be over seven times greater than their respective diameters.
- After cabling is fixed, the bend radius of a common coaxial cable should be over seven times greater than its diameter. The bend radius of this type of cables that often bend or suffer removal/insertion should be over 10 times greater than its diameter.
- The bend radius of a high-speed cable (SFP+ cable, for example) should be over five times greater than its diameter. The bend radius of this type of cables that often bend or suffer removal/insertion should be over 10 times greater than its diameter.

Requirement for the Minimum Fiber Bend Radius

- The diameter of a fiber tray to hold fibers should be over 25 times greater than the diameter of the fiber.
- When an optical fiber is moved, the bend radius of the fiber should be over 20 times greater than the diameter of the fiber.
- During cabling of an optical fiber, the bend radius of the fiber should be over 10 times greater than the diameter of the fiber.

Precautions for Bundling up Cables

- Before cables are bundled, correctly mark labels and stick the labels to cables wherever appropriate.
- Cables should be neatly and properly bundled, and no twisting or bending is allowed, as shown in Figure D-1.

Figure D-1 Bundling up cables (1)

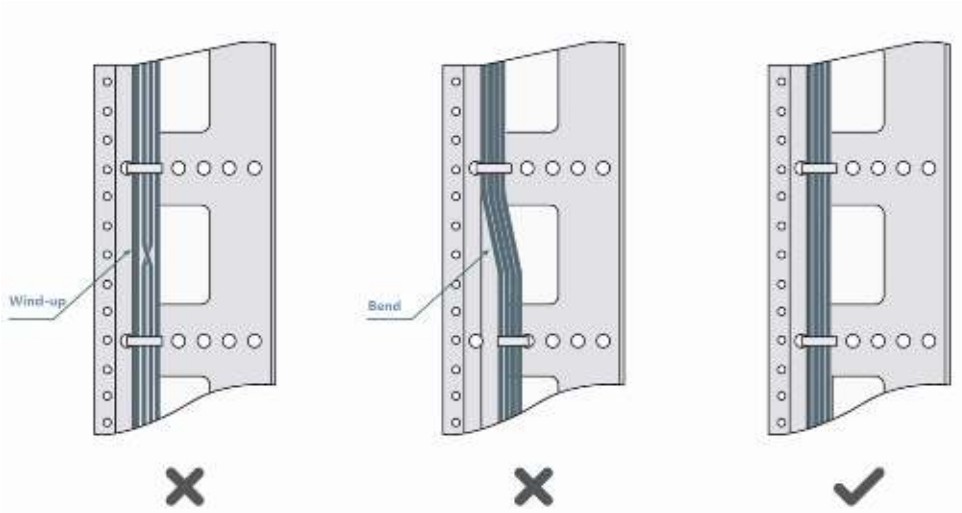

- Cables of different types (such as power cords, signal cables, and grounding cables) should be separated in cabling and bundling and no mixed bundling is allowed. When they are close, crossover cabling can be adopted. In the case of parallel cabling, power cords and signal cables should maintain a distance not less than 30 mm.
- The binding rack and cabling slot inside and outside the cabinet should be smooth without sharp corners.
- The metal hole traversed by cables should have a smooth and fully rounding surface or an insulated lining.
- Proper buckles should be selected to bundle up cables. It is forbidden to connect two or more buckles to bundle up cables.
- After bundling up cables with buckles, you should cut off the remaining part. The cut should be smooth and trim, without sharp corners, as shown in Figure D-2.

Figure D-2 Bundling up cables (2)

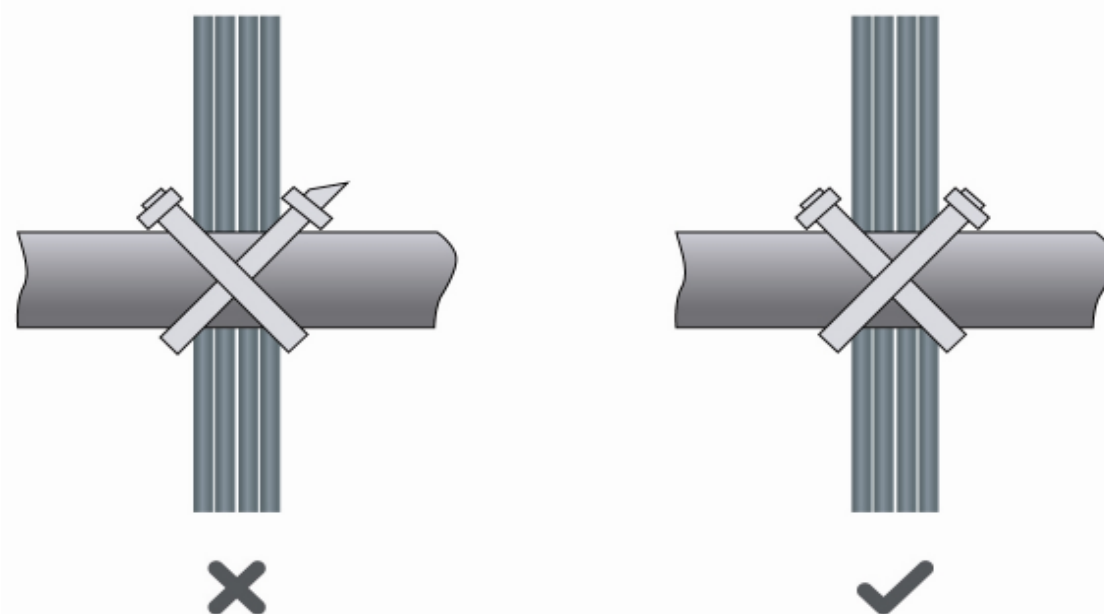

- When cables need to be bent, you should first bundle them up. However, the buckle cannot be bundled within the bend area. Otherwise, considerable stress may be generated in cables, breaking cable cores. As shown in Figure D-3.

Figure D-3 Bundling up cables (3)

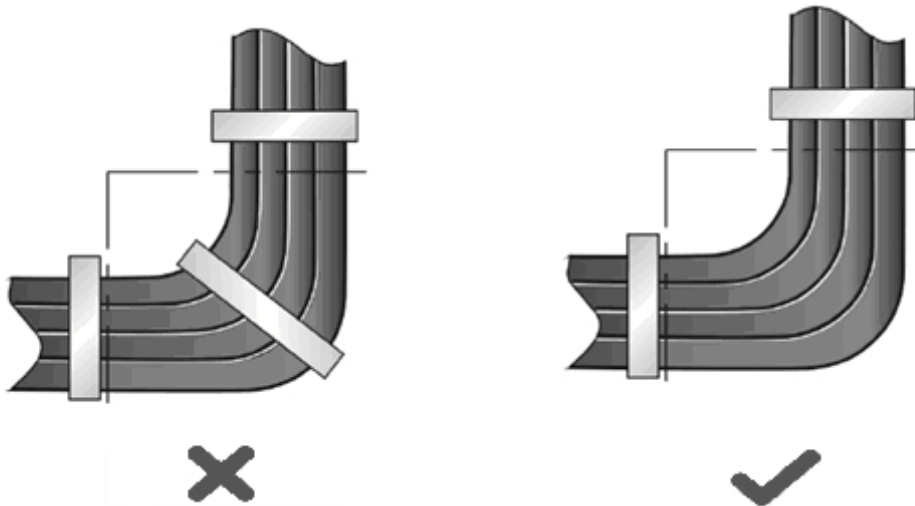

- Cables not to be assembled or remaining parts of cables should be folded and placed in a proper position of the cabinet or cabling slot. The proper position indicates a position that will not affect device running or cause device damage or cable damage during commissioning.
- 220V and -48V power cords cannot be bundled on the guide rails of moving parts.
- The power cables connecting moving parts such as door grounding wires should be reserved with some access after assembled to avoid suffering tension or stress. When the moving part reaches the installation position, the remaining part should not touch heat sources, sharp corners, or sharp edges. If heat sources cannot be avoided, high-temperature cables should be used.
- When using screw threads to fasten cable terminals, the bolt or screw must be tightly fastened, and anti-loosening measures should be taken, as shown in Figure D-4.

Figure D-4 Cable fastening

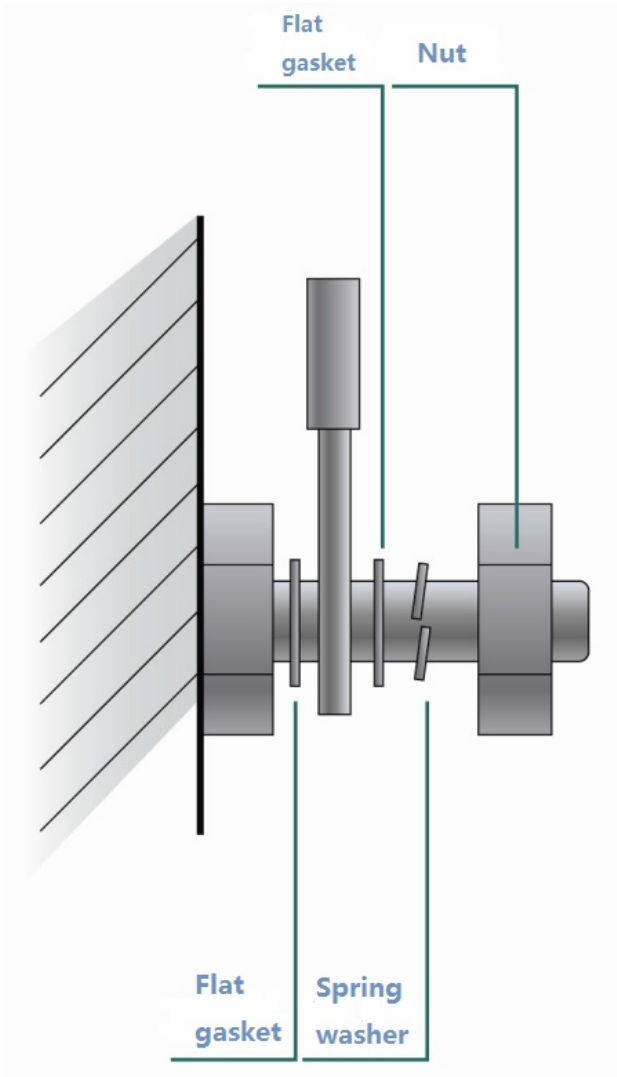

- The hard power cable should be fastened at the terminal connection area to prevent stress on terminal connection and cable.
- Do not use self-tapping screws to fasten terminals.
- Power cables of the same type and in the same cabling direction should be bundled up into cable bunches, with cables in cable bunches clean and straight.
- Binding by using buckles should be performed according to Table D-1.

Cable Bunch Diameter (mm)	Binding space (mm)
10	80-150
10-30	150-200
30	200-300

- No knot is allowed in cabling or bundling.

For wiring terminal blocks (such as air switches) of the cold pressing terminal type, the metal part of the cold pressing terminal should not be exposed outside the terminal block when assembled.

Appendix E: Site Selection

- The machine room should be at least 5km away from the heavy pollution source such as the smelter, coal mine and thermal power plant, 3.7km away from the medium pollution source such as the chemical industry, rubber industry and electroplating industry, and 2km away from the light pollution source such as the food manufacturer and leather plant. If the pollution source is unavoidable, the machine room should be located on the windward side of the pollution source perennially with advanced protection.
- The machine room should be at least 3.7km away from the sea or salt lake. Otherwise, the machine room must be sealed, with air conditioner installed for temperature control. Saline soil cannot be used for construction. Otherwise, you should select devices with advanced protection against severe environment.
- Do not build the machine room in the proximity of livestock farms. Otherwise, the machine room should be located on the windward side of the pollution source perennially. The previous livestock house or fertilizer warehouse cannot be used as the machine room.
- The machine room should be firm enough to withstand severe weather conditions such as windstorm and heavy rain as well as away from dust. If the dust is unavoidable, keep the door and window away from the pollution source.
- The machine room should be away from the residential area. Otherwise, the machine room should meet the construction standard in terms of noise.
- Make sure the air vent of the machine room is away from the sewage pipe, septic tank, and sewage treatment tank. Keep the machine room under positive pressure to prevent corrosive gas from entering the machine room to corrode components and circuit boards. Keep the machine room away from industrial boiler and heating boiler.
- The machine room had better be on the second floor or above. Otherwise, the machine room floor should be 600mm higher than the highest flood level ever recorded.
- Make sure there are no cracks or holes in the wall and floor. If there are cable entries in the wall or window, take proper sealing measures. Ensure that the wall is flat, wear-resistant, and dust-free, which should be up to the standard for flame retarding, soundproofing, heat absorption, dust reduction, and electromagnetic shielding.
- Keep the door and the window closed to make the machine room sealed.
- The steel door is recommended for soundproofing.
- Sulfur-containing materials are forbidden.
- Pay attention to the location of the air conditioner. Keep the air conditioner from blowing wind straight toward the device or blowing water drops from the window or air vent toward the device.