



**Ruijie RG-EAP602 Series Access Points
Hardware Installation and Reference Guide**

Copyright statement

Ruijie Networks©2021

Ruijie Networks reserves all copyrights of this document. Any reproduction, excerpt, backup, modification, transmission, translation or commercial use of this document or any portion of this document, in any form or by any means, without the prior written consent of Ruijie Networks is prohibited.

Exemption statement

This document is provided "as is". The contents of this document are subject to change without any notice. Please obtain the latest information through the Ruijie Networks website. Ruijie Networks endeavors to ensure content accuracy and will not shoulder any responsibility for losses and damages caused due to content omissions, inaccuracies or errors.

Preface

Thank you for using our products. This manual will guide you through the installation of the access point.

Scope

It is intended for the users who have some experience in installing and maintaining network hardware. At the same time, it is assumed that the users are already familiar with the related terms and concepts.

Obtaining Technical Assistance

- Ruijie Networks Website: <https://www.ruijienetworks.com/>
- Technical Support Website: <https://ruijienetworks.com/support>
- Case Portal: <https://caseportal.ruijienetworks.com>
- Community: <https://community.ruijienetworks.com>
- Technical Support Email: service_rj@ruijienetworks.com
- Skype: [service_rj@ruijienetworks.com](https://www.skype.com/people/service_rj@ruijienetworks.com)

Related Documents

Documents	Description
Configuration Guide	Describes network protocols and related mechanisms that supported by the product, with configuration examples.
Command Reference	Describes the related configuration commands, including command modes, parameter descriptions, usage guides, and related examples.

Documentation Conventions

The symbols used in this document are described as below:

 This symbol brings your attention to some helpful suggestions and references.

 This symbol means that you must be extremely careful not to do some things that may damage the device or cause data loss.

1 Product Overview

The RG-EAP602, adhering to the latest 802.11ac Wave2 standard, delivers up to 866Mbps@5G + 300Mbps@2.4G access rate. EAP602 supports security, radio frequency (RF) control, mobile access, Quality of Service (QoS) and seamless roaming. Teaming up with Ruijie RG-WS Wireless Controller Series, wireless data forwarding, high performance security and access control can be accomplished with ease. EAP602 supports PoE to take over challenges in a wide variety of deployment scenarios, including large-scaled campuses, enterprises, hospitals and WIFI hotspots.

1.1 Technical Specifications

Table 1-1 RG-EAP602 Technical Specifications

Model	RG-EAP602
Dimensions	222 mm × 200 mm × 166 mm
Access Rate	Built-in antenna:1166Mbps 2.4GHz: up to 300Mbps 5GHz: up to 866Mbps
Operating Frequency	802.11b/g/n: 2.4 GHz to 2.483 GHz 802.11a/n/ac: 5.150 GHz to 5.350 GHz, 5.47 GHz to 5.725 GHz, 5.725 GHz to 5.850 GHz (Country-Specific)
Maximum Transmit Power	500mW
Antenna Type	Built-in omnidirectional antenna
Antenna Gain	2.4 GHz: 3 dBi 5 GHz: 4 dBi
Coverage Angle	2.4G: E:30°; H:360° 5G: E:30°; H:360°
Ports	One 10/100/1000 Base-T uplink Ethernet port One 10/100/1000 Base-T Ethernet port
FIT/FAT Mode	Not support
LED	System and port status indicators
PoE Power Supply	IEEE 802.3af
Power Consumption	Maximum: 12.95W
Temperature	Operating: -40°C to 65°C (-40°F to 149°F) Storage: -40°C to 85°C (-40°F to 185°F)
Humidity	Operating: 0% to 100% (non-condensing) Storage: 0% to 100% (non-condensing)
IP Rating	IP68
Weight	< 1kg (host)
Safety Standards	GB4943 EN60601-1-2 UL/CSA 60950-1 EN/IEC 60950-1

	EN/IEC 60950-22
EMC Standards	GB9254-2008
	EN301 489
	EN 55022
	FCC Part15
	RSS-210

Table 1-2 LEDs of RG-EAP602

Indicator	Status	Meaning
WiFi (Blue)	Blinking	Data is transmitted by WiFi.
	Solid on	WiFi is enabled and no data is transmitted.
	Off	WiFi is disabled.
WARN(Red)	Blinking	Initialization: blinking at a rate of 1Hz (on for 505ms and off for 505ms). Restore factory settings: blinking at a rate of 14Hz (on for 20ms and off for 50ms). System upgrade: blinking at a rate of 10Hz (on for 40ms and off for 60ms).
	Solid on	CWMP is not connected.
	Off	Powered off or initialization test is normal.
LAN 1(Blue)	Blinking	The port is up and data is transmitted.
	Solid on	The port is up and no data is transmitted.
	Off	The port is not connected.
LAN 2(Blue)	Blinking	The port is up and data is transmitted.
	Solid on	The port is up and no data is transmitted.
	Off	The port is not connected.

1.2 Product Appearance

Figure 1-1 Product Appearance of the RG-EAP602





Figure 1-2 Ports of RG-EAP602

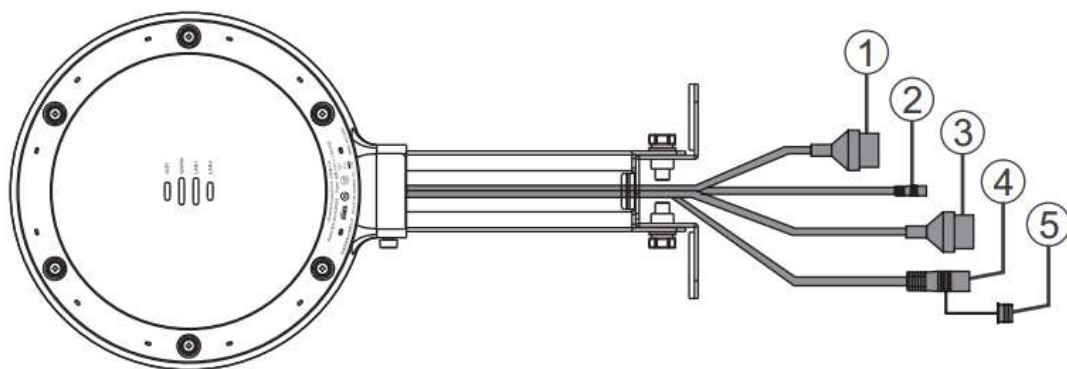



Note	
1. 10/100/1000BASE-T Ethernet port	4. Reset button
2. DC power supply port	5. Waterproof cap
3. 10/100/1000BASE-T Ethernet port/PoE port	

1.3 Power Supply

The AP supports 802.3af PoE or 12V DC power supply (If needed, you can buy the adapter from Ruijie).

- i When PoE power supply is adopted, please make sure the peer end support 802.3af too.
- i The lowest current output requirement for a DC power supply is 1.5A.

2 Preparing for Installation

-
-  To prevent device damage and physical injury, please read carefully the safety recommendations described in this chapter.
 -  Recommendations do not cover all possible hazardous situations.
-

2.1 Grounding and Lightning Protection

- Ensure that both the power-receiving end and the power-supplying end are well-grounded.
- Keep the grounding connection within 30 m, and use a 40mm x 4mm or 50mm x 5mm ground bar of hot-dip zinc-coated flat steel sheet.
- When the connection cable between the main grounding conductor and local equipotential earthing terminal board (LEB) on each floor is shorter than 2 meters, use a stranded copper wire with a sectional area not less than 1.318 mm² (16 AWG) for the connection cable.
- Use a shielded network cable if possible, ensure that devices connected to both ends of the shielded network cable are reliably grounded, and make sure that the sheath of the shielded network cable is also grounded if possible. If no shielded network cable is available, wire the network cable through a steel pipe and bury the steel pipe for lead-in, and properly ground both ends of the steel pipe.
- No additional lightning protector is required as a high-profile lightning protector is built in the RG-EAP602, and the power port support 6kV lightning protection. If a lightning protector of a higher profile is available, configure the lightning protector optionally. Before the configuration, connect the lightning protector to the ground cable.
- Use a power cable with the PE end to ground the power supply (AC). Ensure that the PE end is properly grounded, with a ground resistance less than 5 ohms. Do not use a two-wire power cable with only the live (L) wire and neutral (N) wire. Do not connect the N wire to the protection ground cable of other communication devices, and ensure that the L wire and N wire are properly connected.
- Ensure that the ground resistance is less than 5 ohms. In areas with high soil resistivity, reduce the soil resistivity via measures such as spreading resistivity reduction mixture around the grounding conductor.

2.2 Preparing the Installation Site

- Do not expose the AP to high temperature, dust, or harmful gases.
- Do not install the AP in an area prone to fire or explosions.
- Keep the AP away from EMI sources such as large radar stations, radio stations, and substations.
- Do not subject the AP to unstable voltage, vibration, and noises.
- Keep the AP at least 500 meters away from the ocean and do not face it towards the sea breeze.
- The installation site should be protected from water and flooding, seepage, dripping, or condensation.
- The installation site should be selected according to network planning, communications equipment features and considerations such as climate, hydrology, geology, earthquake, electric power, and transportation.

2.2.1 Temperature and Humidity

Table 2-1 Required Temperature and Humidity for the RG-EAP602 Series

Operating Temperature	-40°C to 65°C (-40°F to 149°F)
Operating Humidity	0% to 100% (non-condensing)

2.2.2 Outdoor Installation

The AP can be mounted on a wall or a pole.

2.2.3 Waterproof

Use a seal plug to seal the unused ports.

After using the reset button, please ensure that the cap is put back.

Use a waterproof plug to connect cables to the AP. For details, see Chapter 3 "Installing the Access Point".

2.2.4 EMI

All interference sources (from outside or inside of the device or application system) affect the device by capacitive coupling, inductive coupling, or electromagnetic waves.

Electromagnetic interference (EMI) occurs due to electromagnetic radiation or conduction, depending on the transmission path.

Radiation interference occurs when energy (usually radio frequency energy) is emitted from a device and propagated through space to disrupt other devices. The interference source can be part of disrupted system or a fully electrically isolated unit. Conduction interference occurs when interference is transferred from one unit to another through cables, which are usually electromagnetic wires or signal cables connected between the source and the device(s) experiencing interference. Conduction interference often affects the power supply of the device. It is eliminated by using filters. Radiation interference can influence the path of any signal from the device and is difficult to shield.

- Take effective measures against interference from the power grid.
- Keep the AP far away from the grounding or lightning protection devices for power equipment.
- Keep the AP away from high-power radio stations, radar stations, and high-frequency high-current devices.
- Take electrostatic shielding measures.

2.3 Installation Tools

Table 2-2 Installation Tools

Tools	Marker, Phillips (crosshead) screwdriver, slotted screwdriver, drill, paper knife, crimping pliers, diagonal pliers, wire stripper, network cable tester, related power and fiber cables, wrench, hammer, cable ties, ESD tools, multimeter, waterproof duct tape, waterproof plaster
--------------	---

 The tool kit and cables are customer supplied.

2.4 Checking before Installation

Please check your materials carefully against the package contents. If there are any errors, please contact your distributor.

3 Installing the Access Point

i Before installing the AP, make sure you have carefully read the requirements described in Chapter 2.

3.1 Installation Flowchart

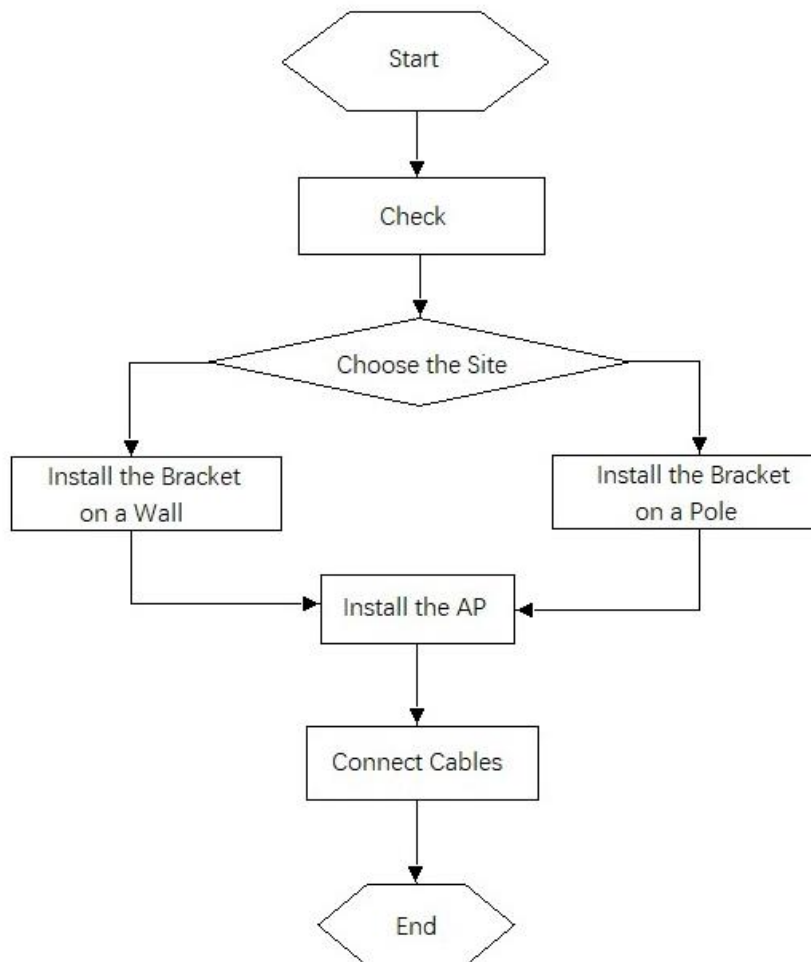

3.2 Before You Begin

Before you install the AP, verify that all the parts in the package contents are there and make sure that:

- The installation site meets temperature and humidity requirements.
- The installation site is equipped with a proper power supply.
- Network cables are in place.

3.3 Precautions

RG-EAP602 can be mounted on a wall and a pole (diameter: 50mm to 70mm, thickness: $\geq 2.5\text{mm}$). Otherwise, the AP could fall down and cause injuries. The installation site can vary due to on-the-spot surveys conducted by technical personnel.

Please make full preparations as described in Chapter 2 and observe the following precautions before installing the AP.

- Before connecting the power supply, make sure the external power supply matches the power module inside the AP.
- Before connecting the power cord, make sure the power switch is in the OFF position.
- When connecting a wire to a binding post, make sure their colors are the same.
- Make sure the power supply is properly connected.

3.4 Installing the AP

- Wall mount

Use M8 x 60 screws to implement the wall mount.

- a. Attach the bracket to the wall and mark the screw hole locations.

Figure 3-1 Installing the Bracket

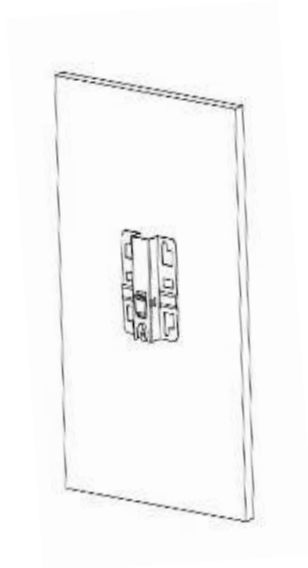

- b. Align the host with bracket and mounting plate to the bracket on the wall, and tighten the M8x40 screws to complete installation.

Figure 3-2 Mounting the Bracket on Wall

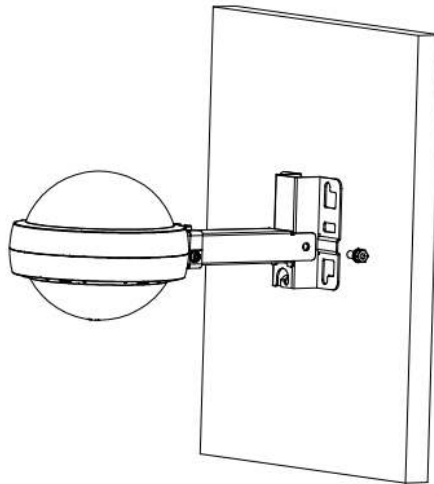

- Pole mount (Vertical)

- Attach the bracket to a pole with hose clamps and fasten the clamps with screws and nuts.

Figure 3-3 Mounting the Bracket on a Pole

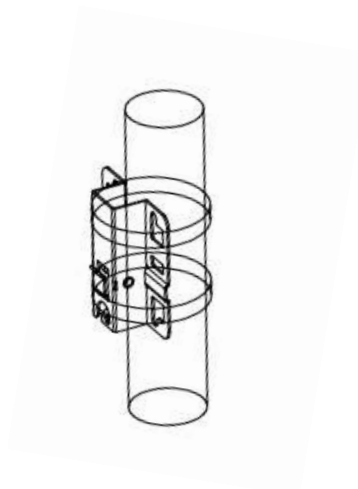

- Align the host with bracket and mounting plate to the bracket on the pole, and tighten the M8×40 screws to complete installation.

Figure 3-4 Vertical Pole Mounting

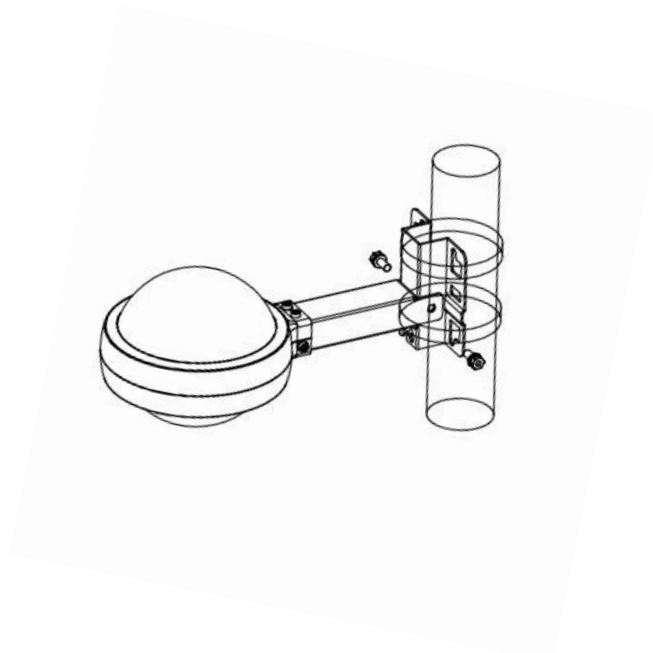

- Pole mount (Horizontal)

Figure 3-5 Mounting the Bracket on a Pole

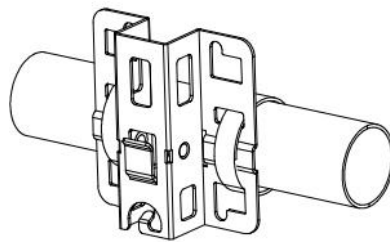
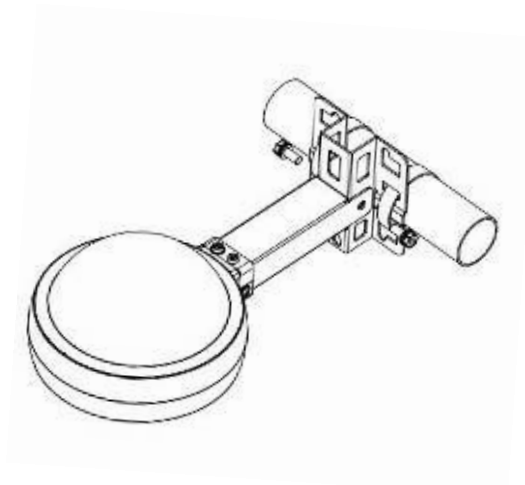



Figure 3-6 Horizontal Pole Mounting



 The horizontal pole mounting is the same with the vertical pole mounting.

3.5 Connecting Cables

Connecting the network cable

i Waterproofing material is customer-supplied.

- 1) Trim the network cable according to the distance between the AP and the power supply. And put the trimmed cable through the bracket.
- 2) Thread the cable with an unprocessed RJ45 through the waterproof plug in the order shown in the Figure 3-7.

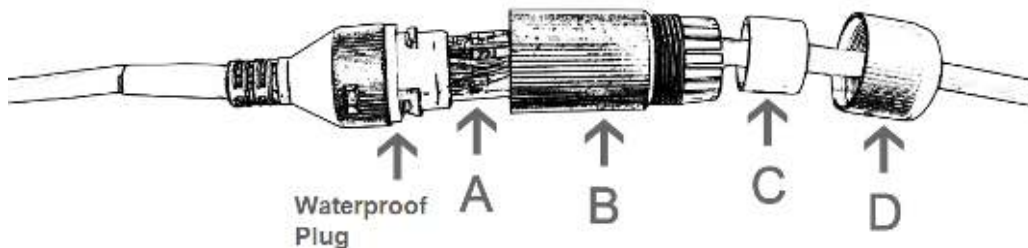

- 3) After the cable passes through the waterproof plug, process the RJ45.
- 4) Connect the cable with the LAN1/PoE/uplink port of AP, and tighten the waterproof plug in the order of B, C and D to complete the installation.
- 5) To install the waterproof port not connected with the network cable: Insert the waterproof rubber rod into the ring, and tighten them in order.

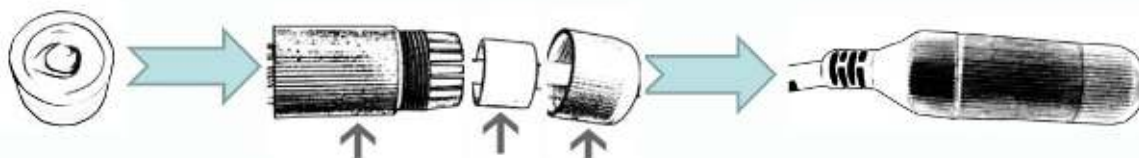

- !** Make sure the plug is correctly inserted. The plug can be damaged if the liquid-tight adapter is improperly tightened.
- !** Before removing the network cable, dismantle the waterproof plug first and then the plug.

Note

The product should not be installed in the place prone to water accumulation, seepage, dripping, and condensation. The product is recommended to be installed horizontally. If any requirement above can not be fulfilled, please use waterproof duct tape and waterproof plaster.

Appendix A Connectors and Media

1000BASE-T/100BASE-TX/10BASE-T

The 1000BASE-T/100BASE-TX/10BASE-T is a 10/100/1000 Mbps auto-negotiation port that supports auto MDI/MDIX.

Compliant with IEEE 802.3ab, 1000BASE-T requires Category 5e 100-ohm UTP or STP (STP is recommended) with a maximum distance of 100 meters (328 feet).

1000BASE-T requires all four pairs of wires be connected for data transmission, as shown in Figure A-1.

Figure A-1 1000BASE-T Connection

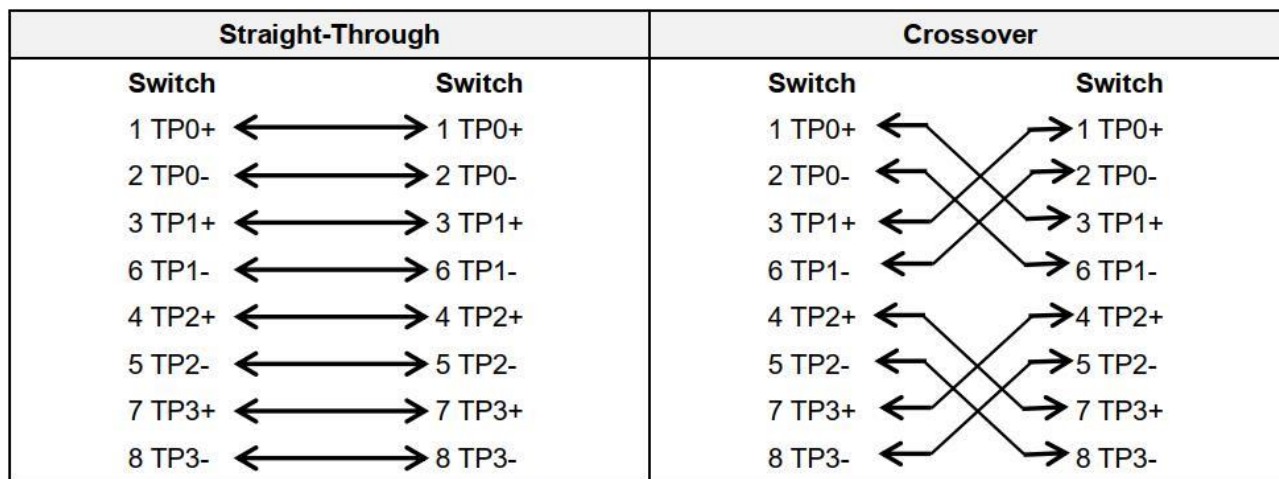

10BASE-T uses Category 3, 4, 5 100-ohm UTP/STP and 1000BASE-T uses Category 5 100-ohm UTP/STP for connections. Both support a maximum length of 100 meters. Table A-1 shows 100BASE-TX/10BASE-T pin assignments.

Table A-2 100BASE-TX/10BASE-T Pin Assignments

Pin	Socket	Plug
1	Input Receive Data+	Output Transmit Data+
2	Input Receive Data-	Output Transmit Data-
3	Output Transmit Data+	Input Receive Data+
6	Output Transmit Data-	Input Receive Data-
4,5,7,8	Not used	Not used

Figure A-3 shows wiring of straight-through and crossover cables for 100BASE-TX/10BASE-T.

Figure A-3 100BASE-TX/10BASE-T Connection

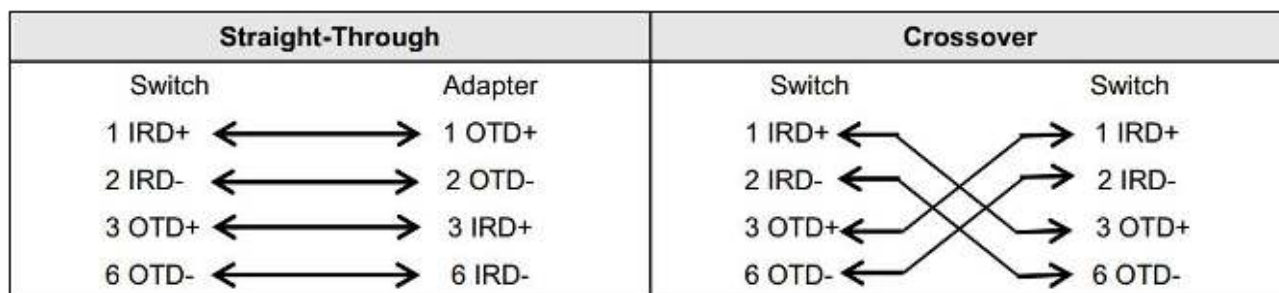

Fiber Connection

You can choose to use single mode or multimode fibers according to the transceiver module types. Figure A-4 shows connection of fiber cables.

Figure A-4 Fiber Connection



Appendix B Mini-GBIC Module Specifications

Ruijie provides various Gigabit SFP transceivers (Mini-GBIC modules) for interfaces of wireless access controllers. You can select the most suitable SFP modules as needed. This appendix describes the models and specifications of some of the Gigabit SFP transceivers for your reference.

Mini-GBIC (SFP) Models and Specifications

Table B-1 Models and Specifications of SFP Modules

Mini-GBIC(SFP)	Wavelength (nm)	Fiber Type	Core Size (micron)	Modal Bandwidth (MHz/km)	Cable Distance	Max Transmit (dBm)	Max Receive (dBm)	Standards	
FE-SFP-LX-MM1310	1310	MMF ¹	62.5/125	—	2 km	-14	-14	IEEE802.3	
FE-SFP-LH15-SM1310	1310	SMF ²	9/125	—	15 km	-8	-8		
MINI-GBIC-SX-MM850	850	MMF ¹	62.5 62.5 50.0 50.0	160 200 400 500	220 m 275 m 500 m 550 m	-4	-17		
MINI-GBIC-LX-SM1310	1310	MMF ¹ SMF ²	62.5 50.0 50.0 9/10	500 400 500 —	550 m 550 m 550 m 10 km	-3	-20		
MINI-GBIC-LH40-SM1310	1310	SMF ²	9/125	—	40 km	3	-3		
MINI-GBIC-ZX50-SM1550	1550	SMF ²	—	—	50 km	0	-22		
MINI-GBIC-ZX80-SM1550					80 km	4.7	-22		
MINI-GBIC-ZX100-SM1550					100 km	5	-9		
Mini-GBIC-GT	—	Cat 5 UTP	—	—	100 m	—	—		

¹ MMF=Multimode fiber

² SMF=Single mode fiber

 When using shorter distances of single-mode fiber for optical SFP transceivers with cable distance greater than 40 km (including 40 km), you may need to insert an in-line optical attenuator in the link to avoid overloading the receiver.